

DIGITAL COMMUNICATION LAB

STATE INSTITUTE OF TECHNICAL TEACHERS TRAINING AND RESEARCH

GENERAL INSTRUCTIONS

Rough record and Fair record are needed to record the experiments conducted in the laboratory. Rough records are needed to be certified immediately on completion of the experiment. Fair records are due at the beginning of the next lab period. Fair records must be submitted as neat, legible, and complete.

INSTRUCTIONS TO STUDENTS FOR WRITING THE FAIR RECORD

In the fair record, the index page should be filled properly by writing the corresponding experiment number, experiment name, date on which it was done and the page number.

On the **right side** page of the record following has to be written:

1. **Title:** The title of the experiment should be written in the page in capital letters.
2. In the left top margin, experiment number and date should be written.
3. **Aim:** The purpose of the experiment should be written clearly.
4. **Apparatus/Tools/Equipments/Components used:** A list of the Apparatus/Tools/ Equipments /Components used for doing the experiment should be entered.
5. **Principle:** Simple working of the circuit/experimental set up/algorithm should be written.
6. **Procedure:** steps for doing the experiment and recording the readings should be briefly described(flow chart/programs in the case of computer/processor related experiments)
7. **Results:** The results of the experiment must be summarized in writing and should be fulfilling the aim.
8. **Inference:** Inference from the results is to be mentioned.

On the **Left side** page of the record following has to be recorded:

1. **Circuit/Program:** Neatly drawn circuit diagrams/experimental set up.
2. **Design:** The design of the circuit/experimental set up for selecting the components should be clearly shown if necessary.

3. **Observations:**

- i) Data should be clearly recorded using Tabular Columns.
- ii) Unit of the observed data should be clearly mentioned
- iii) Relevant calculations should be shown. If repetitive calculations are needed, only show a sample calculation and summarize the others in a table.

4. **Graphs:** Graphs can used to present data in a form that show the results obtained, as one or more of the parameters are varied. A graph has the advantage of presenting large amounts of data in a concise visual form. Graph should be in a square format.

GENERAL RULES FOR PERSONAL SAFETY

1. Always wear tight shirt/lab coat, pants and shoes inside workshops.
2. REMOVE ALL METAL JEWELLERY since rings, wrist watches or bands, necklaces, etc. make excellent electrodes in the event of accidental contact with electric power sources.
3. DO NOT MAKE CIRCUIT CHANGES without turning off the power.
4. Make sure that equipment working on electrical power are grounded properly.
5. Avoid standing on metal surfaces or wet concrete. Keep your shoes dry.
6. Never handle electrical equipment with wet skin.
7. Hot soldering irons should be rested in its holder. Never leave a hot iron unattended.
8. Avoid use of loose clothing and hair near machines and avoid running around inside lab.

TO PROTECT EQUIPMENT AND MINIMIZE MAINTENANCE:

DO: 1. SET MULTIRANGE METERS to highest range before connecting to an unknown source.

2. INFORM YOUR INSTRUCTOR about faulty equipment so that it can be sent for repair.

DO NOT: 1. Do not MOVE EQUIPMENT around the room except under the supervision of an instructor.

Experiment No.1

SAMPLING AND RECONSTRUCTION OF SINE WAVE

AIM:

To set up sampling and reconstruction circuits to study the sampling theorem and to plot waveforms for different sampling rates.

OBJECTIVES:

After the completion of this experiment, students will have good knowledge about sampling, effect of sampling rate, method of sampling and reconstruction of signals.

COMPONENTS AND EQUIPMENTS REQUIRED:

Sl. No.	Item & Specification	Quantity
1	FET BFW 10	1No.
2	Resistor- 1K, 56 Ω	1No.
3	Capacitor- 1 μ F	1No.
4	Signal Generator	2Nos.
5	CRO	1No.
6	Bread Board	1No.
7	Wires and probes	

THEORY:

As a first step to convert analog signals into digital form, the samples of the analog signals are taken at regular intervals. The levels of these samples are then encoded and send to the receiver. At the receiver these samples are recovered and from that the original signal is reconstructed. Sampling theorem states that the original signal can be faithfully reconstructed only if the sampling frequency is at least double that of the highest frequency component in the sampled signal.

A sampling and reconstruction circuit is shown in figure. An FET is used as a switch to take samples of the sine wave input. Sampling pulses are applied to the gate of the FET that switches it ON and OFF. The input signal is sent to the output only when the transistor is ON. Thus the output of the FET is a sampled form of the input signal.

The reconstruction circuit is a low pass filter having a cut off frequency equal to the frequency of the analog input signal.

PROCEDURE:

1. Test all the components and probes.
2. Set up the circuit as shown in figure on the bread board.
3. Feed 5Vpp, 100Hz sine wave as input.
4. Apply 5 Vpp square wave signal as sampling pulse.
5. Observe sampled output and reconstructed signals for the following sampling frequencies; a) 100Hz b) 200Hz c) 500Hz d) 1 KHz and e) 2KHz. Vary the amplitude of the sampling pulses to obtain the optimum output.
6. Plot the above waveforms.

CIRCUIT DIAGRAM:

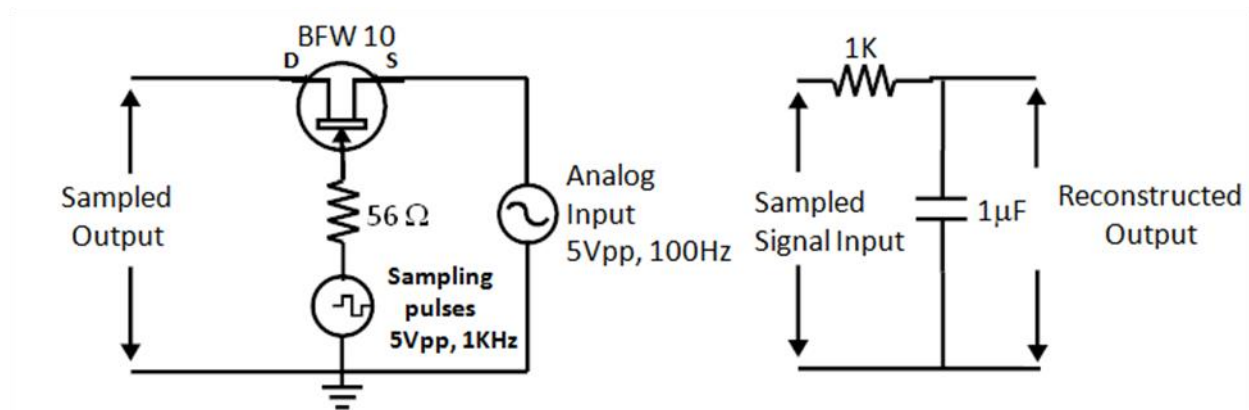

WAVEFORMS:

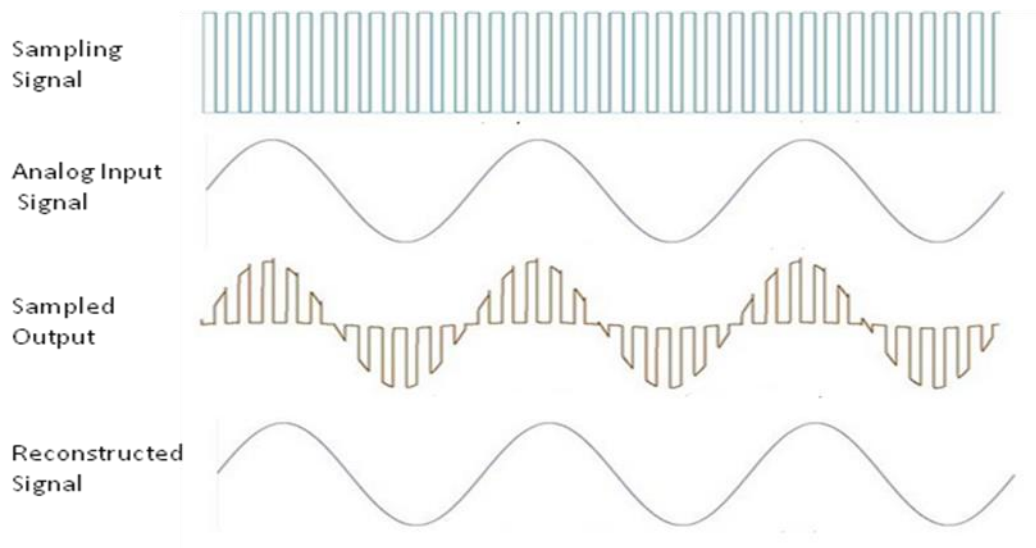

RESULT:

Analog Input is sampled at different sampling rates and then reconstructed. Observed the waveforms and plotted.

INFERENCE:

- 1) To reconstruct the original signal, the sampling frequency should at least be double that of the input frequency.
- 2) Reconstructed signal quality improves with increase in sampling frequency.

Experiment No.2**PULSE AMPLITUDE MODULATOR AND DEMODULATOR**

AIM: To set up pulse amplitude modulator and demodulator circuits and to observe the waveforms.

OBJECTIVES: After completing this experiment, students will be able to set up PAM modulator and demodulator circuits and identify the waveforms.

COMPONENTS AND EQUIPMENTS REQUIRED:

Sl. No.	Item & Specification	Quantity
1	Analog Switch CD 4016	1No.
2	Resistor- 1.5K	1No.
3	Capacitor- 1 μ F	1No.
4	Signal Generator	2Nos.
5	CRO	1No.
6	Bread Board	1No.
7	Power supply +/- 10V	1No.

THEORY:

Pulse Amplitude Modulation (PAM) is the simplest pulse modulation scheme. In pulse amplitude modulation system the amplitude of a carrier pulse train is varied in accordance with the instantaneous level of the modulating signal.

The simplest form of the PAM modulator is an analog switch that is turned on and off at the RF carrier pulse rate. As the switch changes state, the modulating signal is connected and disconnected from the output. Thus the output PAM signal is a sampled version of the modulating signal. If the sampling frequency is sufficiently high (at least twice that of the highest modulating frequency), the original signal can be recovered at the receiver by simply passing it through a low pass filter having a cut-off frequency equal to the highest frequency in the modulating signal.

CIRCUIT DIAGRAM:

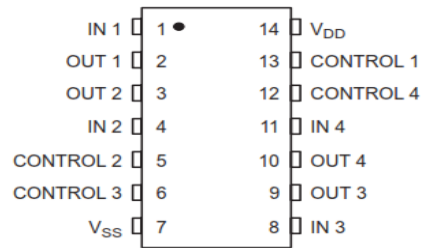
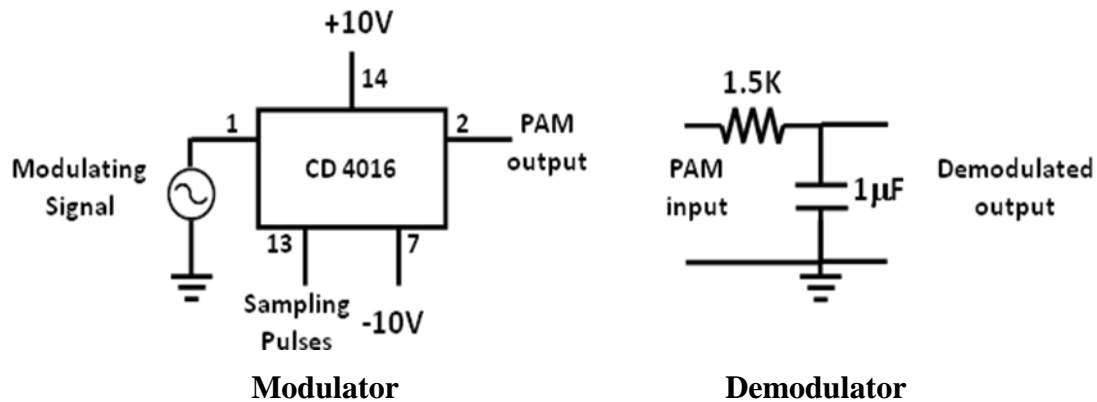

CD 4016 Pinout

PROCEDURE:

1. Test all the components and probes.
2. Set up the modulator circuit using CD 4016 as shown in figure. Switch on the power supplies.
3. Feed 5V_{pp}, 100Hz modulating signal at IN 1 input and 5V, 1KHz square wave signal at Control 1 input of CD 4016.
4. Observe the PAM output signal at OUT 1 pin on one channel of the CRO.
5. Set up the demodulator circuit as shown in figure. Feed the PAM signal as the input and observe the demodulated output on the other channel of the CRO. Plot the waveforms.

WAVEFORMS:

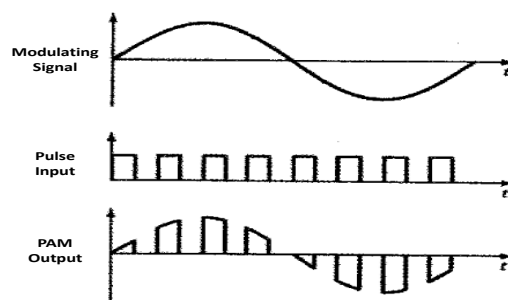

RESULT:

The PAM modulator and demodulator circuits were set up and the waveforms were plotted.

INFERENCE: Analog switch can be used as a PAM modulator and a simple RC low pass filter can be used as a PAM demodulator.

Experiment No.3**PULSE WIDTH MODULATOR AND DEMODULATOR**

AIM: To set up pulse width modulator and demodulator circuits and to observe and plot the waveforms.

OBJECTIVES: After completing this experiment the students will be able to set up pulse width modulator and demodulator circuits and to identify PWM waveform.

COMPONENTS AND EQUIPMENTS REQUIRED:

Sl. No.	Item & Specification	Quantity
1	IC 555, IC 741	1No. each
2	Resistor- 1.2K, 4.7K, 10K, 1.5K 1K	1No. each 2Nos.
3	Capacitor- 0.1 μ F, 0.001 μ F 10 μ F, 1 μ F	1No. each 2Nos.each
4	Diode 1N 4001	1No.
5	CRO	1No.
6	Signal Generator	2Nos.
7	Bread Board	1No.
8	Power Supply 10V	1No.
9	Wires and connectors	

THEORY:

Pulse Width Modulation (PWM) is a form of pulse modulation where the width of the pulses in a carrier pulse train is made proportional to the instantaneous amplitude of the modulating signal.

A pulse width modulator circuit made up of 555 Timer is shown in figure. Here the 555 timer is working in monostable mode. A negative trigger pulse at pin 2 sets the output. The modulating signal is applied to the control pin of the 555 which varies the threshold voltage. This in turn varies the charging time of capacitor C2 and makes the trailing edge of the output pulse proportional to the modulating signal. Thus the leading edge of the output pulse is decided by the

trigger pulse which occurs periodically and the trailing edge is proportional to the amplitude of the modulating signal. The resulting output will be pulse width modulated.

The pulse width demodulator circuit consists of an integrator and a low pass filter with a cut off frequency of 100Hz. The integrator reconstructs the modulating signal which is further smoothed by the low pass filter. The series capacitor eliminates the dc component from the demodulated signal.

PROCEDURE:

1. Test all the components and probes.
2. Set up the circuit as shown in the figure on the bread board. Switch on the power supply.
3. Feed 10Vpp, 1 KHz square wave signal at the trigger input and 5Vpp, 100Hz sine wave at the control input.
4. Observe the input modulating signal, carrier pulse train and the PWM output signal on CRO. Vary the modulating signal amplitude to get the optimal output. Plot the waveforms.

CIRCUIT DIAGRAM:

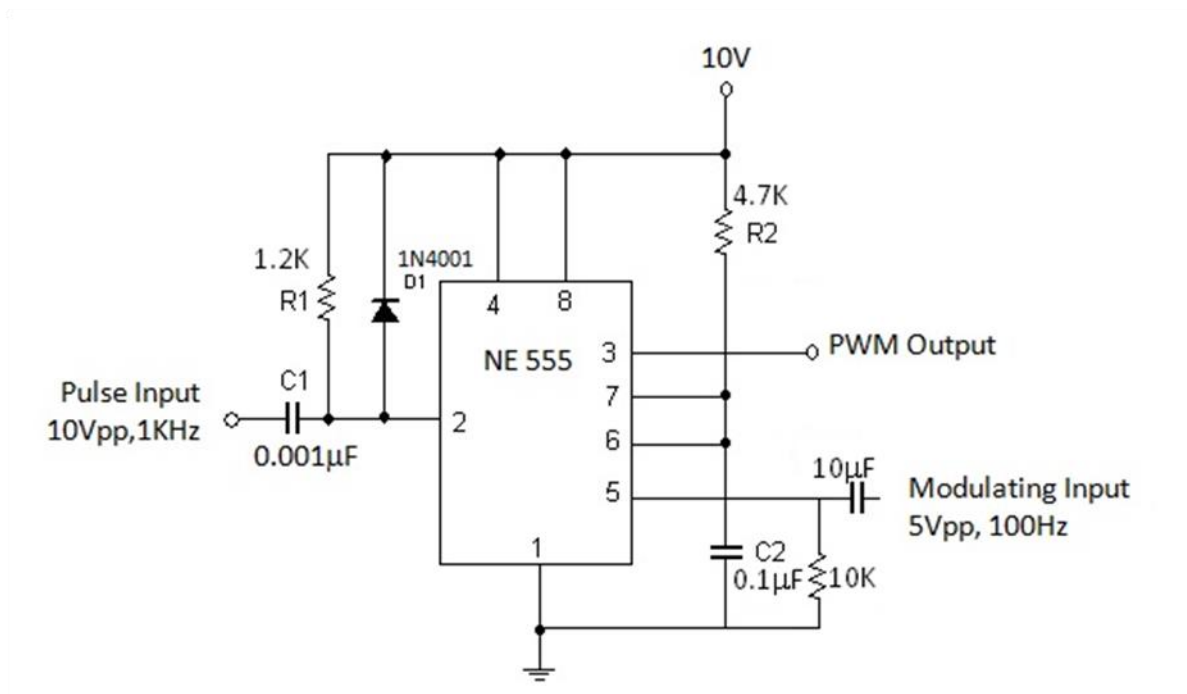

Modulator

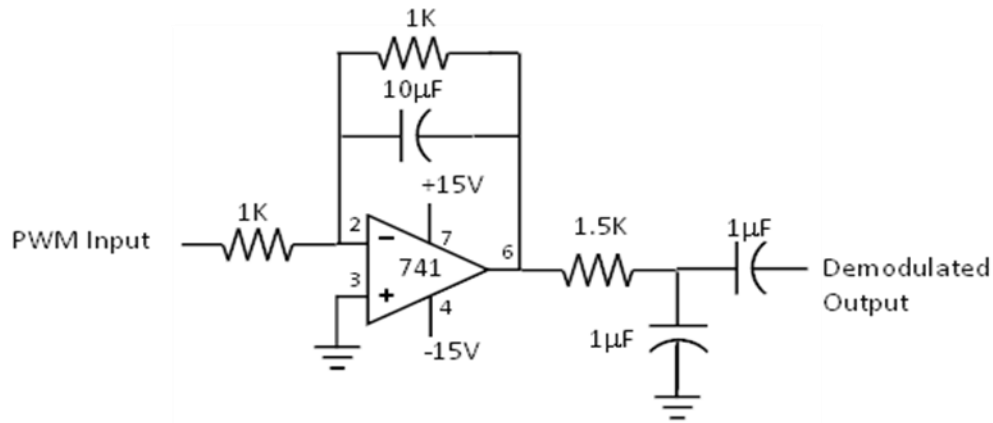

Demodulator

WAVEFORM:

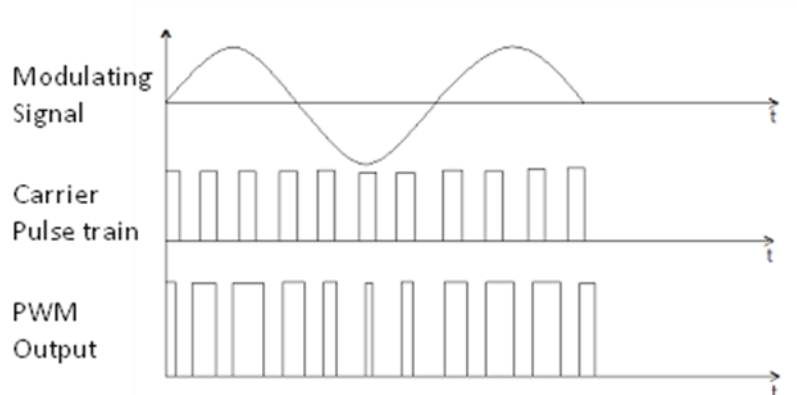

RESULT:

Pulse width modulator circuit was set up and the waveforms were observed and plotted.

INFERENCE: Learned the usage of 555 timer as a pulse width modulator.

Experiment No.4

PULSE POSITION MODULATOR AND DEMODULATOR

AIM: To set up pulse position (PPM) modulator and demodulator circuits and to observe and plot the waveforms.

OBJECTIVES: After completing this experiment the students will be able to set up pulse position modulator circuit using IC 555, demodulator using transistor and to identify PPM waveform.

COMPONENTS AND EQUIPMENTS REQUIRED:

Modulator

Sl. No.	Item & Specification	Quantity
1	IC 555	2Nos.
2	Resistor- 4.7K,10K, 1.2K	2No. each
3	Capacitor- 10 μ F, 0.01 μ F 0.1 μ F, 0.001 μ F	1No. each 2Nos.
4	Diode 1N 4001	2Nos.
5	CRO	1No.
6	Signal Generator	1Nos.
7	Bread Board	1No.
8	Power Supply 10V	1No.
9	Wires and connectors	

Demodulator

Sl. No.	Item & Specification	Quantity
1	IC 741, IC LM324	1No.each
2	Resistor-1.5K, 47K, 15K, 100K 1K,10 Ω	1No. each 2Nos.
3	Capacitor- 10 μ F 1 μ F	1No. 2Nos.
4	CRO	1No.
5	Bread Board	1No.
6	Power Supply 10V, +/- 15V	1No.each
7	Wires and connectors	

THEORY:

Pulse Position Modulation (PPM) is one of the pulse modulation schemes where the relative position of the pulses in a carrier pulse train is made proportional to the instantaneous value of the modulating signal.

A pulse position modulator made up of IC 555 is shown in figure. Both the 555s are working in monostable mode. The first monostable generates a PWM signal and this PWM output is used as the trigger input of the second monostable. Since the monostable triggers at the trailing edge of the PWM signal, the position of the resulting pulses will have position shift compared to the input pulse train.

The PPM demodulator is set up using an Op Amp SR flip flop, an integrator and a low pass filter. The flip flop is set by the carrier pulses and reset by the PPM pulses. The resulting

output is a PWM signal. This PWM signal is then demodulated using the integrator-low pass filter combination.

PROCEDURE:

1. Test all the components and probes.
2. Set up the circuit as shown in the figure on the bread board. Switch on the power supplies.
3. Feed the 10Vpp, 1KHz, 0.2 duty cycle carrier pulse train and the 5Vpp, 100Hz modulating signal (Sine wave) at the trigger and control inputs of the first 555 respectively.
4. Make sure that the PWM signal is available at pin 3 of the first 555. Vary the amplitude of the modulating signal to get a proper PWM output if needed.
5. Observe the waveforms of the input pulse train, modulating input, PWM output and PPM output on the CRO.
6. Observe the following waveforms in pairs on both the channels of the CRO; a) Modulating input and PWM output b) PWM output and PPM output c) Modulating input and PPM output
7. Plot the waveforms.
8. Set up the demodulator circuit as shown in figure. Switch on the power supply.
9. Feed the PPM signal input and the carrier pulse input as shown in figure. Observe the waveforms at various points on CRO and plot.

CIRCUIT DIAGRAM:

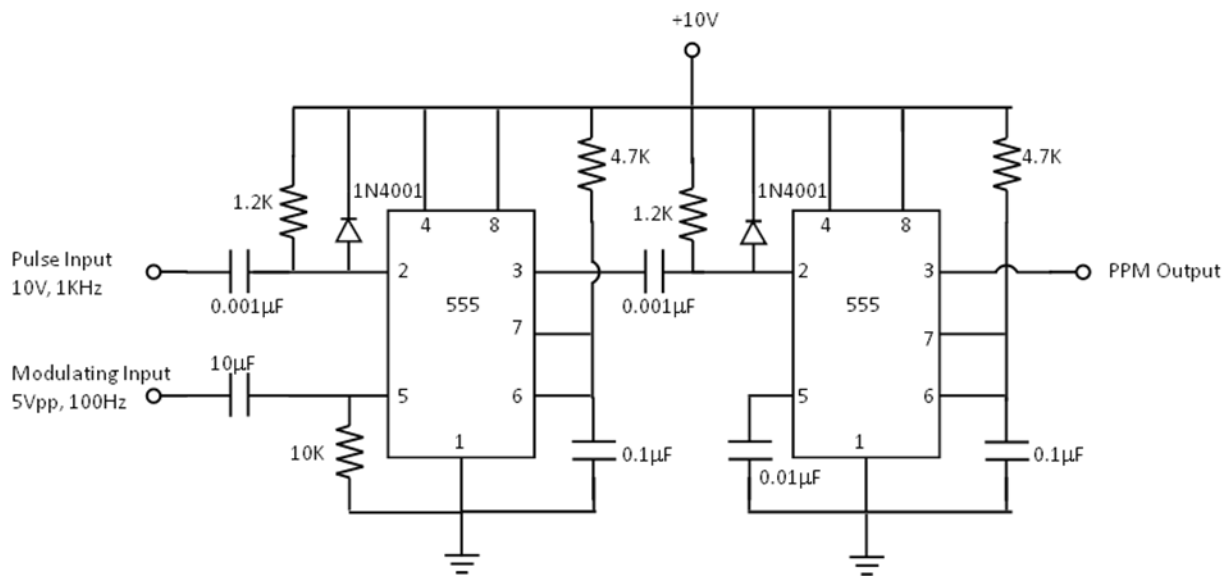

Modulator

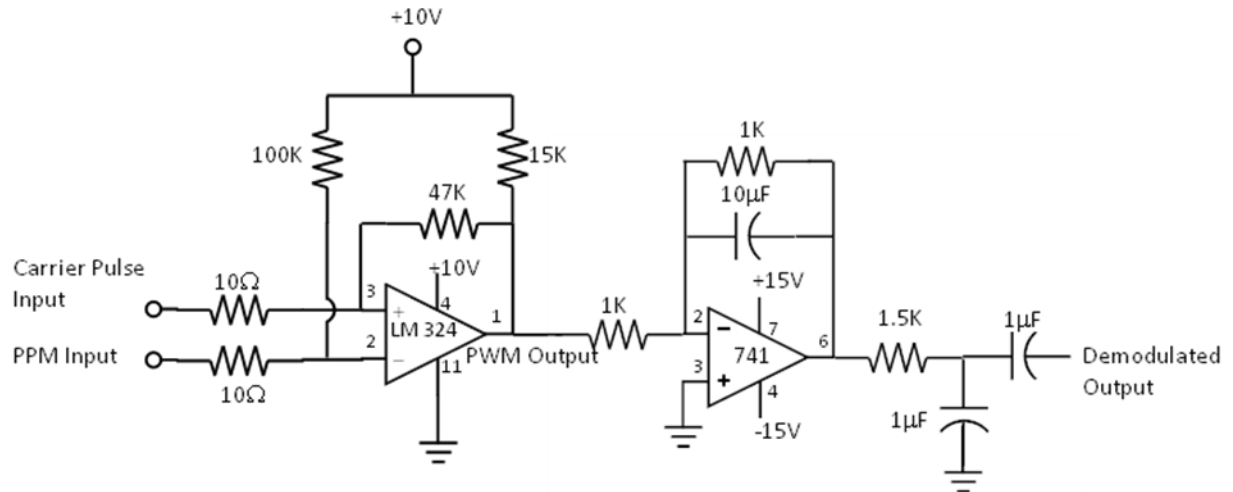

Demodulator

WAVEFORM:

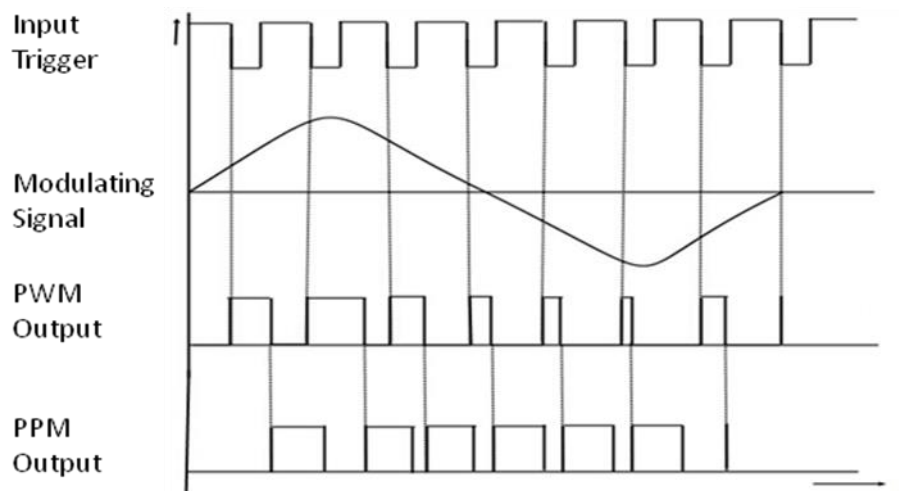

RESULT:

The PPM modulator and demodulator circuits were set up and the waveforms were observed and plotted.

INFERENCE: Studied the usage of 555 timer as PPM modulator.

Experiment No.5

PULSE CODE MODULATION

AIM: To set up a PCM modulator and observe the waveforms.

OBJECTIVES: After completing this experiment, the students will be able to a) Set up a PCM modulator and to generate a PCM encoded output for a given analog input.

COMPONENTS AND EQUIPMENTS REQUIRED:

Sl. No.	Item & Specification	Quantity
1	Resistor- 2.2K 1K	7Nos. 3Nos.
2	IC CD4016, LM324, 7493, 7400	1No.each
3	Signal Generator	3Nos.
4	CRO	1No.
5	Power Supply- +5V	1No.
6	Bread Board	1No.
7	Wires and probes	

THEORY:

Pulse Code Modulation is a digital modulation technique by which an analog signal is converted to an equivalent sequence of binary codes. The analog signal is first sampled at regular intervals and these samples are then quantized to predefined levels. An analog to digital convertor converts these quantized symbols to their corresponding binary codes.

In the circuit an analog switch is used to sample the input signal. These samples are compared to the output of a DAC circuit which is initially zero. So the comparator output goes 'high' and strobes the clock input to the counter. This signal also disables the reset inputs of the counter. The counter starts to count up. An R-2R ladder DAC simultaneously converts the counter output to its equivalent analog value. When the DAC output goes above the input sample, the comparator output switches to 'low' and cuts off the clock input from the counter. The reset inputs are also enabled causing the counter output to reset. When the next sample reaches the comparator input the whole process starts over again.

PROCEDURE:

1. Test all the components and probes.
2. Set up the circuit as shown in figure on a bread board.
3. Feed 2V_{pp}, 100Hz unipolar sine wave as the analog input (Set dc level at 2V to obtain a signal that varies between +1V and +3V). Make sure that the input peak voltage never exceeds the peak DAC output.

4. Use the dc offset knob on the function generator to add dc offset to make unipolar sine wave.
5. Use 4Vpp, 500Hz square wave with 20% duty cycle as sampling clock (clock 1) and 5V, 5KHz square wave as the clock input of the counter (clock 2).
6. Observe the input sine wave, sampled output and the PCM output (DAC output; staircase waveform) on CRO. Vary the analog input and clock 1 input amplitudes to obtain the optimum result, if needed.
7. Plot the waveforms.
8. The binary output can be checked by giving discrete dc input voltages (less than 5V).

CIRCUIT DIAGRAM:

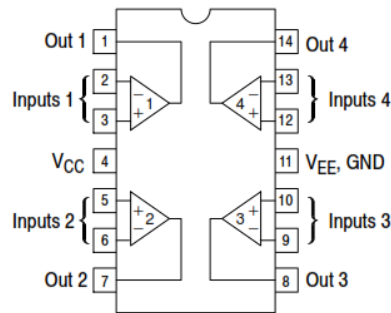

LM 324 Pin Connection

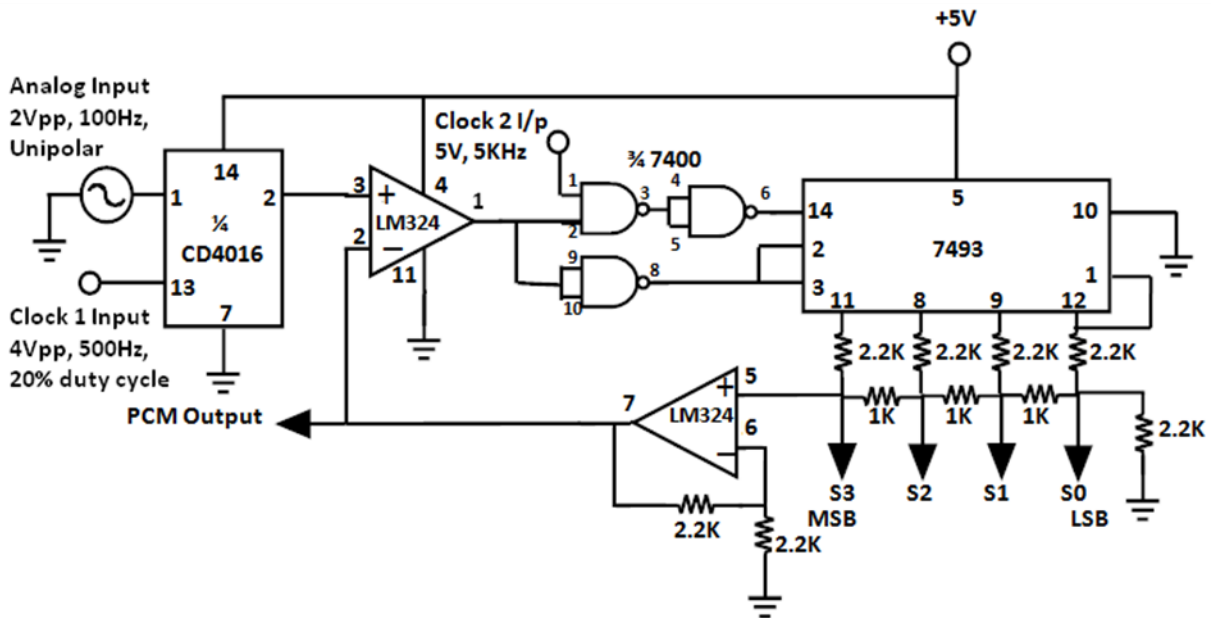

PCM Modulator

WAVEFORM:

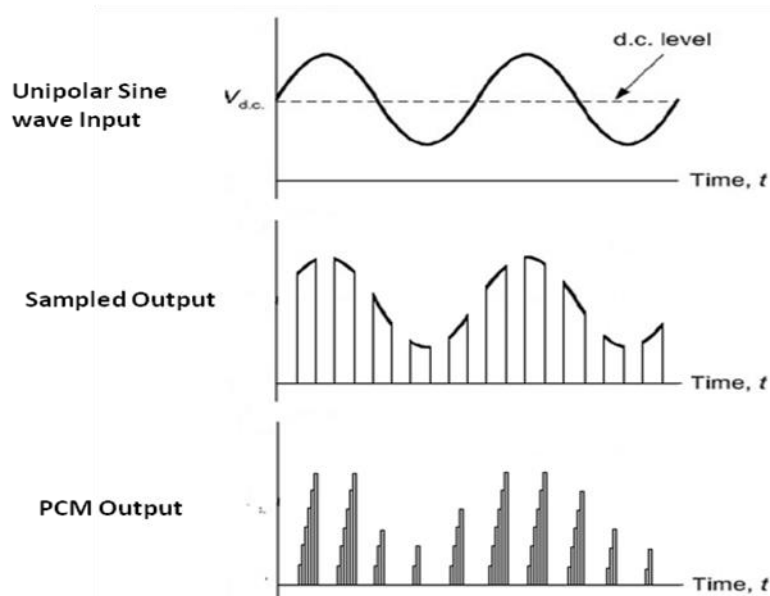

RESULT:

The PCM modulator circuit was set up and the waveforms were plotted.

INFERENCE:

PCM is the actual digital modulation scheme where the analog input is sampled and converted into sequence of binary codes corresponding to the sample amplitudes.

Experiment No.6

ASK MODULATOR AND DEMODULATOR

AIM:

To set up ASK modulator and demodulator circuits and to observe the waveforms.

OBJECTIVES:

After completing this experiment the students will be able to a) Set up ASK modulator and demodulator circuits and b) Identify ASK waveform.

COMPONENTS AND EQUIPMENTS REQUIRED:

Sl. No.	Item & Specification	Quantity
1	Transistor- BC 107	1No.
2	Resistor- 4.7K, 10K, 2.2K, 1K 10K pot	1No. each 1No.

3	Capacitor- 0.01 μ F	1No.
4	Diode- 1N 4001	1No.
5	Zener Diode- 5Z1	2Nos.
6	IC 741	1No.
7	Signal Generator	2Nos.
8	CRO	1No.
9	Power Supply- +/- 15V, 5V	1No. each
10	Bread Board	1No.
11	Wires and probes	

THEORY:

Amplitude Shift Keying (ASK) is a digital modulation scheme where the binary data is transmitted using a carrier signal with two different amplitude levels. For binary 0 and 1, the carrier switches between these two levels. In its simplest form, a carrier is sent during one input and no carrier is sent during the other. This kind of modulation scheme is called on-off keying.

A simple ASK modulator circuit is shown in figure. Here a sinusoidal high frequency carrier signal is sent for logic '0' (-5V) and no carrier is sent for logic '1' (+5V). The transistor works as a switch closes when the input (base) voltage is +5V (logic '1') and shorts the output. When the input voltage is -5V (logic '0'), the switch opens and the carrier signal is directly connected to the output.

The demodulator circuit consists of an envelope detector and a comparator. The diode D selects the positive half cycle of the ASK input. The envelop detector formed by 2.2K resistor and 0.01 μ F capacitor detects the data out of the ASK input. The Op Amp comparator and the zener diode amplitude limiter convert this detected signal to its original logic levels. The 10K potentiometer may be varied to set suitable reference voltage for the comparator.

PROCEDURE:

1. Test all the components, bread board and probes.
2. Set up the circuits as shown in figure on the bread board.
3. Feed 10Vpp, 500Hz square wave as the message/data input and 2Vpp, 5KHz sine wave as the carrier input.
4. Observe both the message input and ASK output simultaneously on CRO and plot.
5. Apply the ASK output of the modulator to the demodulator input.
6. Observe both the ASK input and the demodulated output simultaneously on CRO. Adjust the reference voltage of the comparator if needed.
7. Plot the waveforms.

CIRCUIT DIAGRAM:

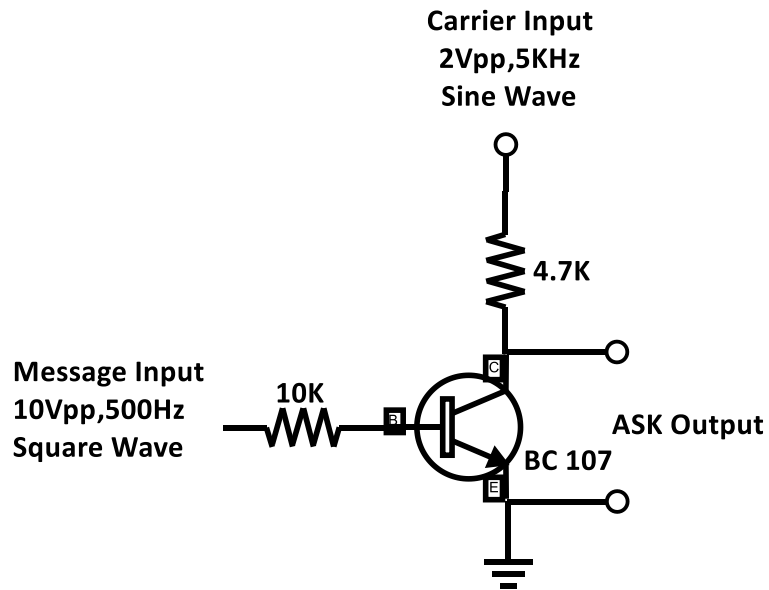

ASK Modulator

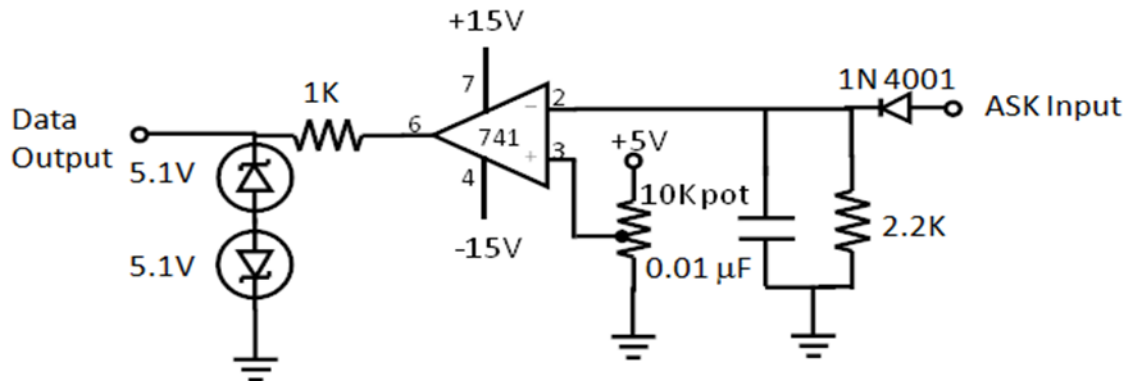

ASK Demodulator

WAVEFORMS:

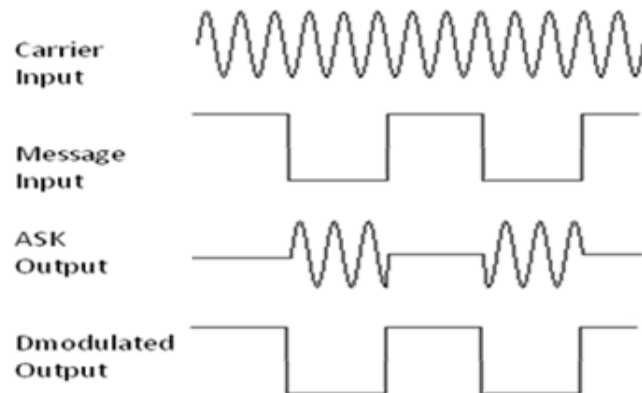

RESULT:

ASK modulator and demodulator circuits were set up and the waveforms were plotted.

INFERENCE: Studied the simplest digital modulation scheme.

Experiment No.7

FREQUENCY SHIFT KEYING

AIM:

To set up FSK modulator and demodulator circuits and to observe the waveforms.

OBJECTIVES:

After completing this experiment, the students will be able to a) Set up FSK modulator and demodulator circuits and b) Identify FSK waveform.

COMPONENTS AND EQUIPMENTS REQUIRED:

Sl. No.	Item & Specification	Quantity
1	Transistor- BC 177	1No.
2	Resistor- 47K, 47K pot, 10K pot 10K	1No. each 7Nos.
3	Capacitor- 0.01 μ F 0.02 μ F 0.047 μ F, 0.001 μ F	3Nos. 4Nos. 1No.each
4	IC LM311	1No.
5	IC 555, IC 565	1No. each
6	Signal Generator	1Nos.
7	CRO	1No.
8	Power Supply- +/- 5V	1No.

9	Bread Board	1No.
10	Wires and probes	

THEORY:

Frequency Shift Keying (FSK) is a digital modulation scheme where the digital data is transmitted using a high frequency carrier signal. For logic '0' and '1' the carrier signal switches between two preset frequencies, hence the name FSK.

A frequency shift keying modulator circuit made up of 555 timer is shown in figure. The 555 works in monostable mode. For logic '1' transistor BC 177 is OFF and the monostable works in normal mode and capacitor C1 charges through R_A and R_B and the output frequency is at the first preset level. For logic '0' the transistor is ON and the resistor R_C comes in parallel with R_A and reduces its effective resistance. The charging rate of the capacitor increases and a higher frequency signal is obtained at the output. This is the second preset frequency level. Thus the output signal switches between the two preset frequencies for logic '0' and '1'. The resulting signal is FSK modulated.

PLL IC 565 is used to demodulate the FSK signal. As the signal appears at the input of 565 PLL, the PLL locks to the input frequency and tracks it between the two possible frequencies with a corresponding dc shift at the output. A three stage RC ladder filter is employed for removing the sum frequency component from the output. The demodulated output is applied to the comparator to restore the required logic levels.

PROCEDURE:

1. Test all the components and probes.
2. Set up the FSK modulator and demodulator circuits on the bread board. Switch on the power supplies.
3. Feed 5V, 100Hz (10Vpp, 100Hz) square wave as the data input. Vary the pot R_C to adjust the output frequencies if needed.
4. Observe both the input and output waveforms on CRO and plot. The waveform of the FSK output will be rectangular in nature for 555 modulator.
5. Apply the FSK output of the modulator to the input of the demodulator, and observe the output. Vary the 10K pot to get the PLL locked with the input signal. Plot the waveforms.

CIRCUIT DIAGRAM:

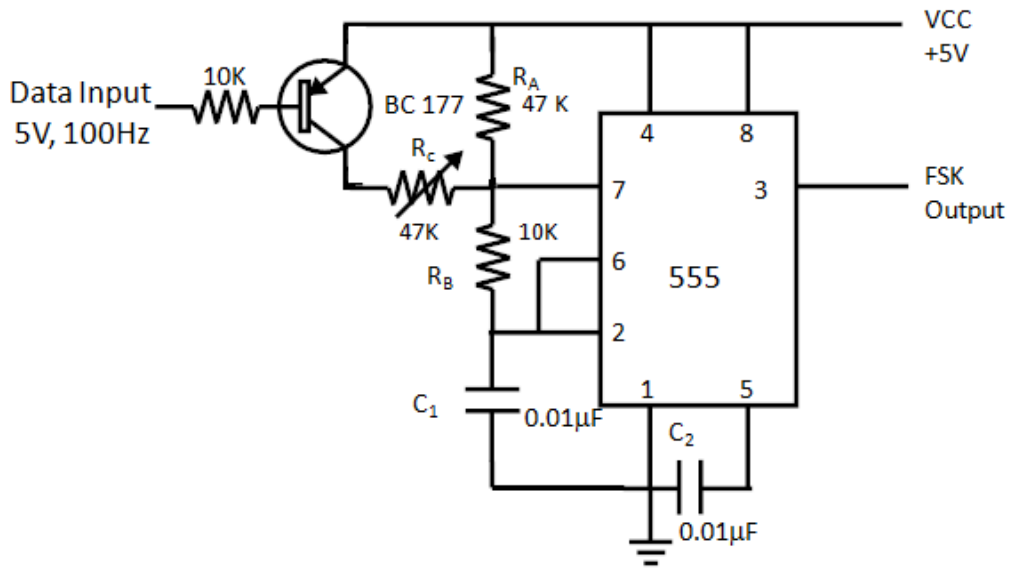

FSK Modulator

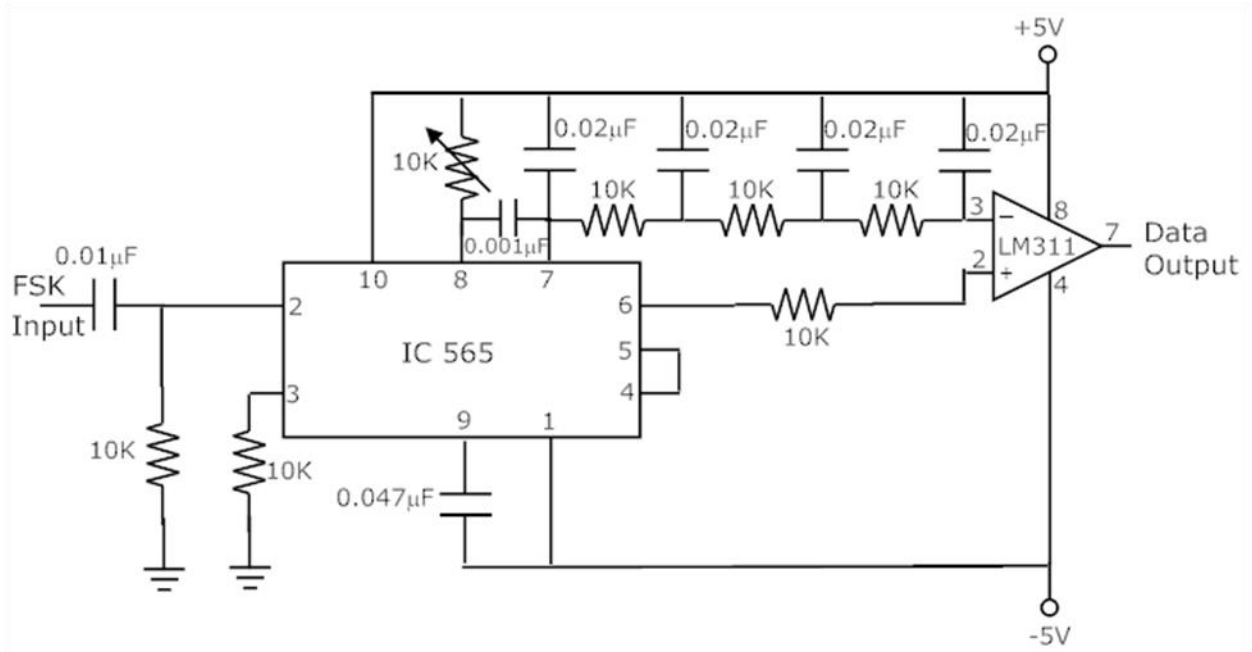

FSK Demodulator

Alternate Circuits

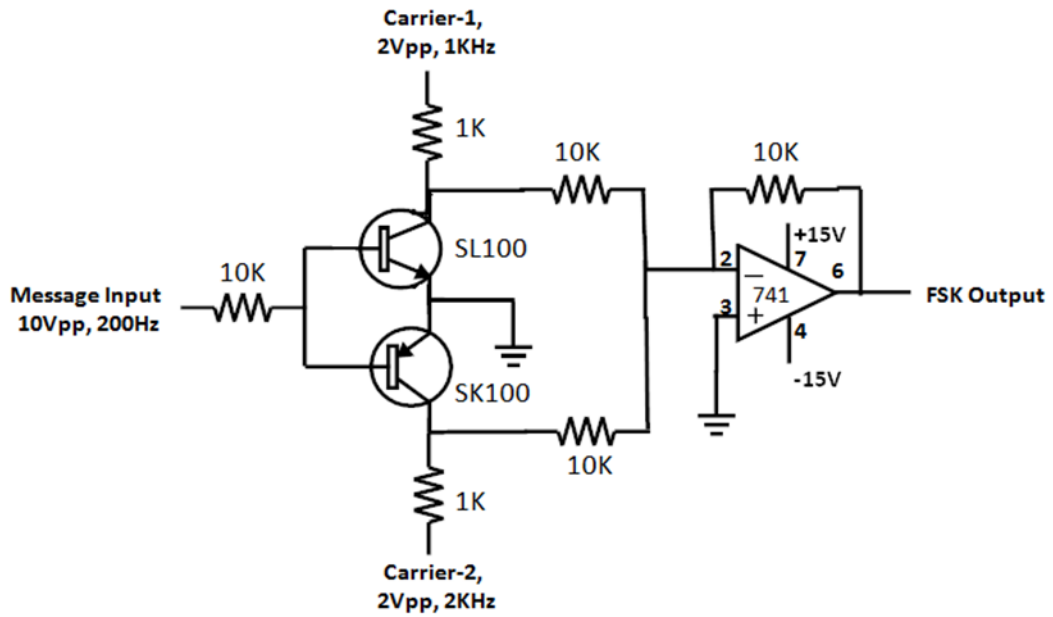

FSK Modulator

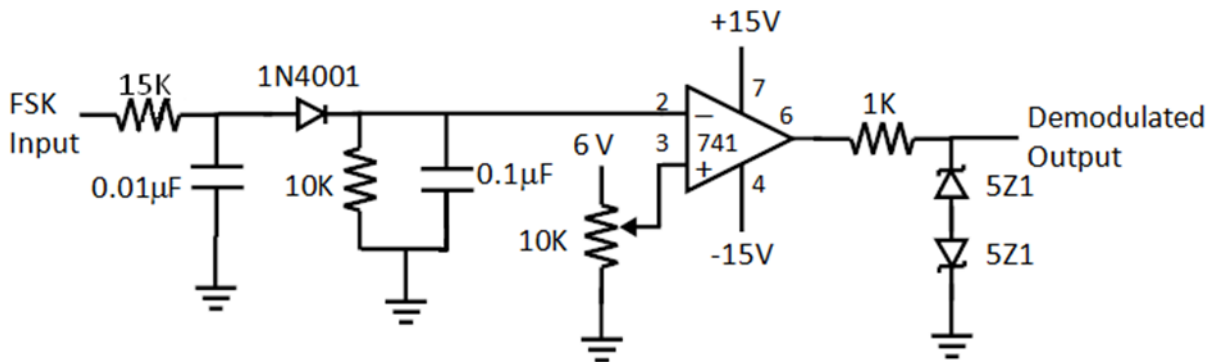

FSK Demodulator

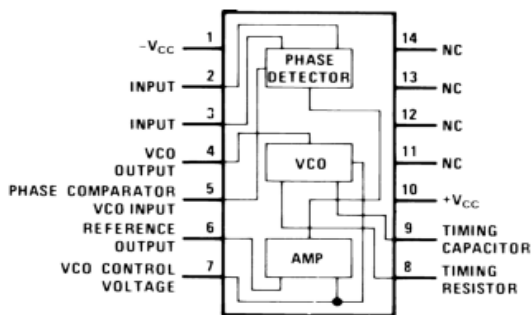

Pinout LM 565

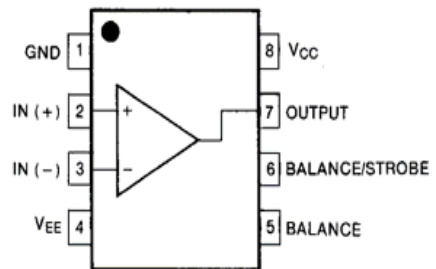

Pinout LM 311

WAVEFORM:

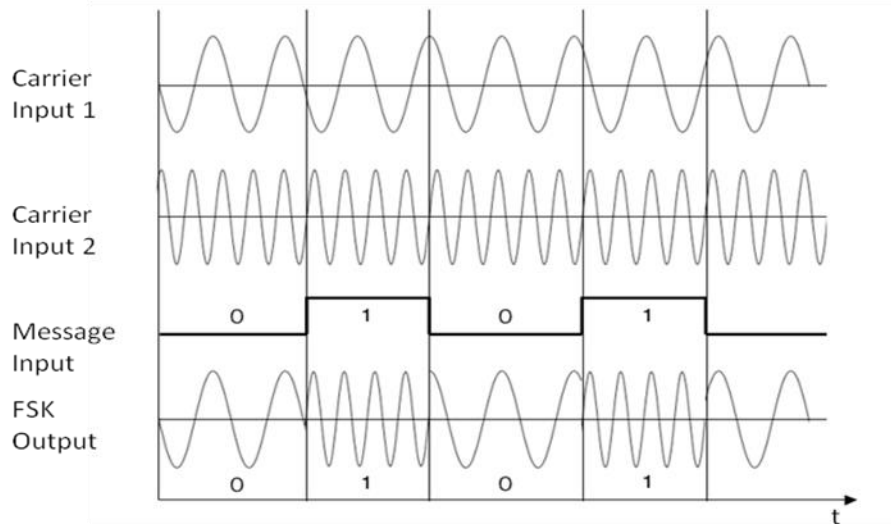

RESULT: The FSK modulator and demodulator circuits were set up and the waveforms were plotted.

INFERENCE: Studied the usage of IC 555 as FSK modulator and LM 565 as FSK demodulator.

Experiment No.8

BINARY PHASE SHIFT KEYING

AIM: To set up Binary Phase Shift Keying (BPSK) modulator and demodulator circuits and to observe the waveforms.

OBJECTIVES: After completing this experiment, the students will be able to a) Set up BPSK modulator and demodulator circuits and b) Identify BPSK waveform.

COMPONENTS AND EQUIPMENTS REQUIRED:

Sl. No.	Item & Specification	Quantity
1	Transistor- SL100, SK100	1No. each
2	Resistor- 10K pot, 100K 1K 10K	1No. each 3No. 7Nos.
3	Capacitor- 0.01 μ F	1No.
4	IC 741	3No.
5	Diode- 1N4001 Zener Diode- 5Z1	1No. 2Nos.
6	Signal Generator	2Nos.
7	CRO	1No.
8	Power Supply- +/- 15V, 2V	1No. each
9	Bread Board	1No.

THEORY:

Binary Phase Shift Keying (BPSK) is digital transmission scheme where the binary data is transmitted using out of phase signals. During logic '0' a preset number of cycles of a sinusoidal carrier signal is transmitted and during logic '1' the same number of cycles of the carrier signal is transmitted but with 180° phase shift.

Modulator

A simple BPSK modulator circuit using an NPN-PNP transistor pair and an Op amp is shown in figure. The transistors work as switches and the Op amp works as inverting/non-inverting amplifier. The carrier signal is fed to the collectors and the message signal is fed to the bases of the two transistors simultaneously. The emitters of the transistors are grounded. When the message signal is at logic '1' (+5V), the NPN transistor is ON and works as a closed switch. The PNP transistor is OFF and works as an open switch. The Op amp now works as a non-inverting amplifier with the carrier signal fed to its non-inverting input. The carrier signal reaches the output without any phase shift. When the message signal is at logic '0' (-5V), the NPN transistor is OFF and the PNP transistor ON. The Op amp works as an inverting amplifier with the carrier signal fed to its inverting pin. The carrier signal now reaches the output with 180° phase shift. Thus the carrier signal switches its phase as the message signal switches between '0' and '1'. The resulting output is BPSK modulated.

Demodulator

The BPSK demodulator circuit shown in figure consists of an Op Amp difference amplifier, a rectifier, an envelope detector and a comparator. The difference amplifier which is fed with the unmodulated carrier signal at the non-inverting input and the BPSK modulated signal at the inverting input passes only the phase shifted signal to the output. The in phase signals get subtracted completely. The envelope detector removes the carrier content and recovers the data information. The comparator inverts and level limits the signal to regain the correct logic level.

PROCEDURE:

1. Test all the components and probes.
2. Set up the circuits on the bread board as shown in figure.
3. Feed 2Vpp, 1KHz sine wave as carrier input and 10Vpp, 200Hz square wave signal as the message input.
4. Observe the BPSK output on CRO and plot the waveforms.
5. Feed this BPSK modulated signal to the inverting input of the demodulator. Also feed the unmodulated carrier signal (2Vpp, 1KHz) to the non-inverting input.
6. Observe waveforms on CRO. Adjust the potentiometer to obtain the correct output (if needed).
7. Plot the waveforms.

CIRCUIT DIAGRAM:

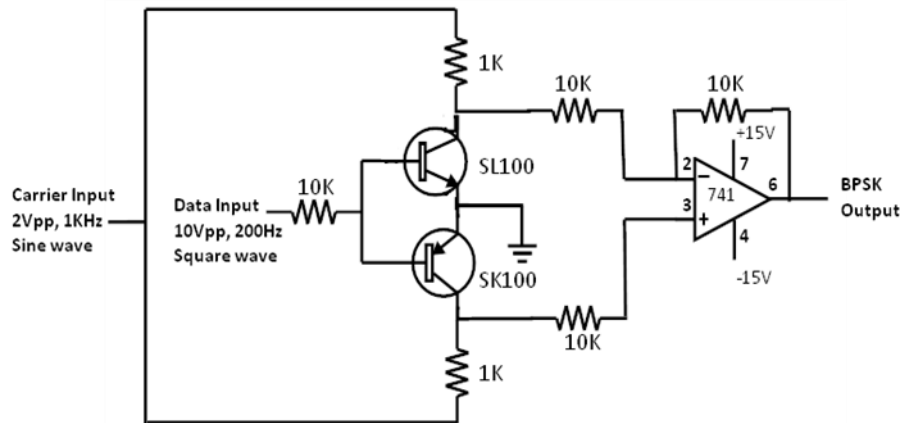

BPSK Modulator

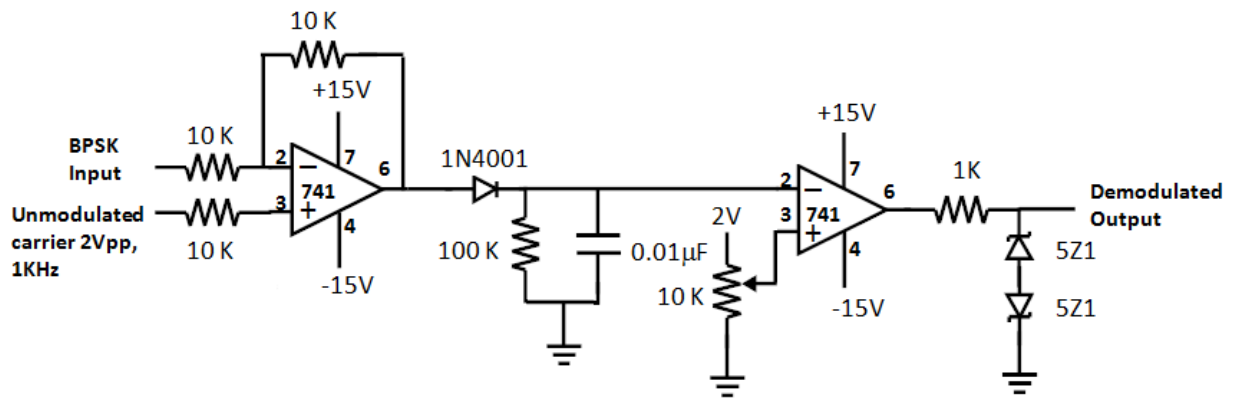

BPSK Demodulator

WAVEFORMS:

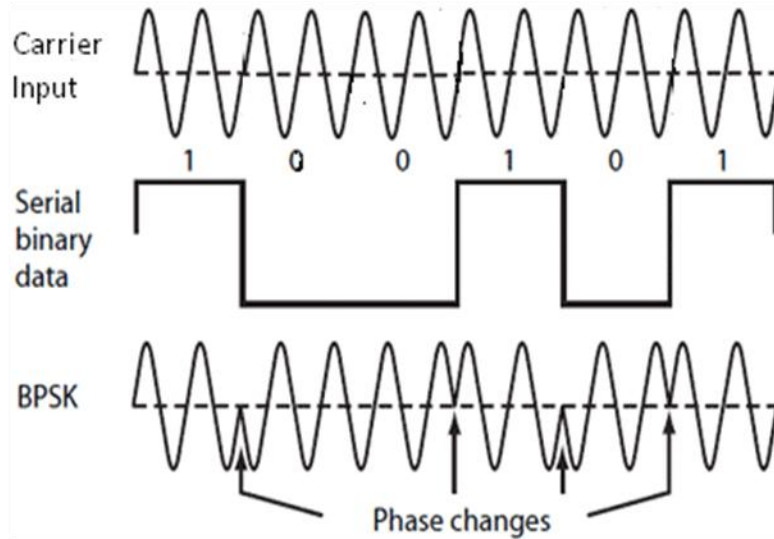

RESULT:

BPSK modulator and demodulator circuits were set up and the waveforms were plotted.

INFERENCE: Studied how digital data is transmitted using BPSK.

Experiment No.9

TIME DIVISION MULTIPLEXER AND DEMULTIPLEXER

AIM:

To set up Time Division Multiplexer and Demultiplexer circuits and to observe the waveforms.

OBJECTIVES: After completing this experiment, the students will be able to a) Set up TDM multiplexer and demultiplexer circuits.

COMPONENTS AND EQUIPMENTS REQUIRED:

Sl. No.	Item & Specification	Quantity
1	Transistor- SL100, SK100	1No. each
2	Resistor- 1K 10K	7Nos. 4Nos.
3	Capacitor- 1 μ F	2No.
4	IC 741	1No.
5	Signal Generator	3Nos.
6	CRO	1No.
7	Power Supply- +/- 15V	1No.
8	Bread Board	1No.
9	Wires and probes	

THEORY:

Time Division Multiplexing (TDM) is widely used in digital communication networks to transmit multiple signals simultaneously through the same channel. Different signals are transmitted in a time shared manner. Each signal is allotted a fixed time slot and a sample of the corresponding signal is transmitted during that period. After one sample each of all the signals is sent, the time slot is given back to the first signal and this process repeats.

TDM Multiplexer

A simple TDM multiplexer circuit using an NPN-PNP transistor pair and an Op amp is shown in figure. The transistors work as switches and the Op amp works as an adder. The signals to be sent are fed to the collectors of the two transistors. The switching signal is applied to the bases of the transistors. During the ON time of the switching signal, the NPN transistor is ON and the PNP transistor is OFF. Signal 1 alone is connected to the adder input and reaches the output. During OFF time of the switching signal, the NPN transistor is OFF and the PNP transistor is ON. Signal 2 alone is connected to the adder input and reaches the output. Thus the two signals reach the output one after the other as the switching signal changes state. The resulting signal is a time division multiplexed one. The on-off period of the switching signal decides the time slot.

TDM Demultiplexer

In the demodulator circuit the two transistors act as switches. They connect the input TDM signal to the respective outputs alternately as the switching signal changes state. A square wave signal with the same phase and frequency as the one used at the TDM modulator is used as the switching signal. During the ON time of the switching signal, the NPN transistor is ON and the PNP transistor is OFF. TDM input is now connected to signal 1 output. During the OFF time of the switching signal, the NPN transistor is OFF and the PNP transistor is ON. TDM input is now connected to signal 2 output. The RC networks act as low pass filters.

PROCEDURE:

1. Test all the components and probes.
2. Set up the circuits on the bread board as shown in figure.
3. Connect 5Vpp, 2KHz square wave signal as the switching input.
4. Connect 2Vpp, 100Hz sine wave as signal 1 and 2Vpp, 100Hz square wave as signal 2.
5. Observe the TDM output on CRO and plot the waveforms.
6. Feed this TDM output to the input of the demultiplexer. Use the same square wave signal used at the modulator as the switching signal.
7. Observe signal 1 and signal 2 outputs of the demultiplexer on CRO.
8. Plot the waveforms.

CIRCUIT DIAGRAM:

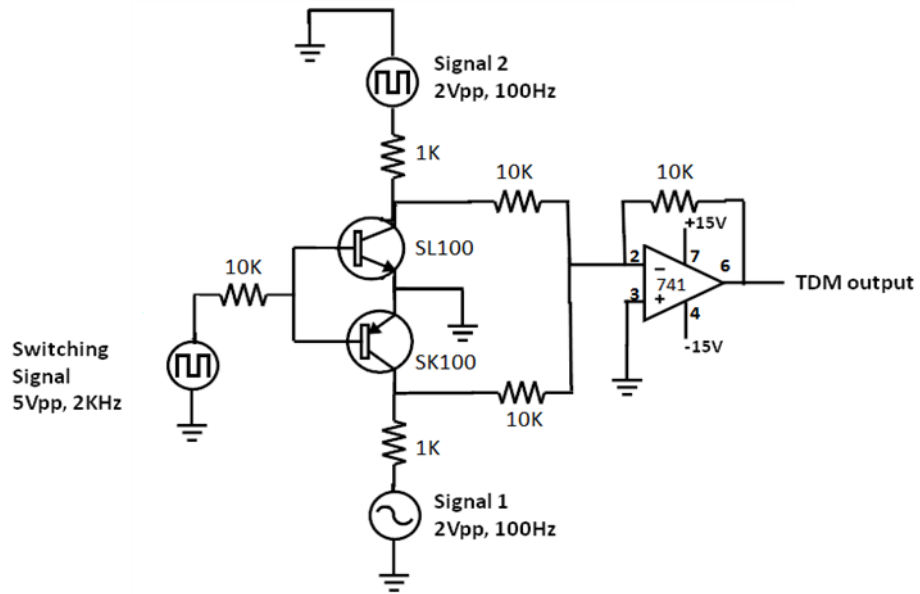

TDM Multiplexer

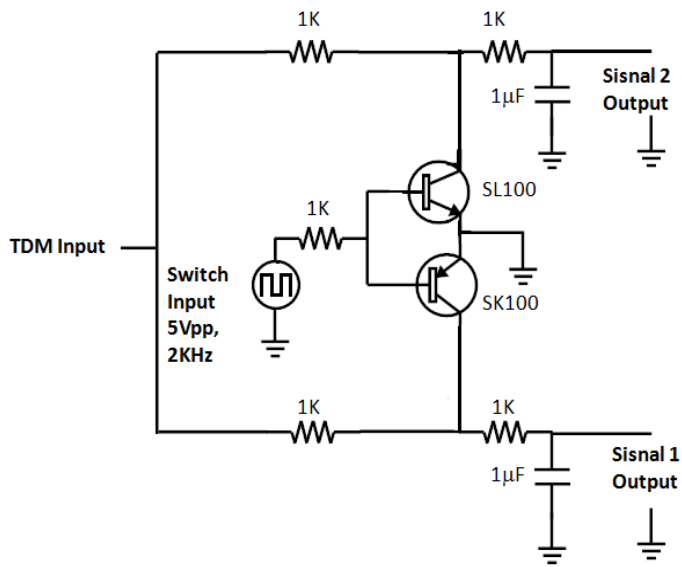

TDM Demultiplexer

WAVEFORM:

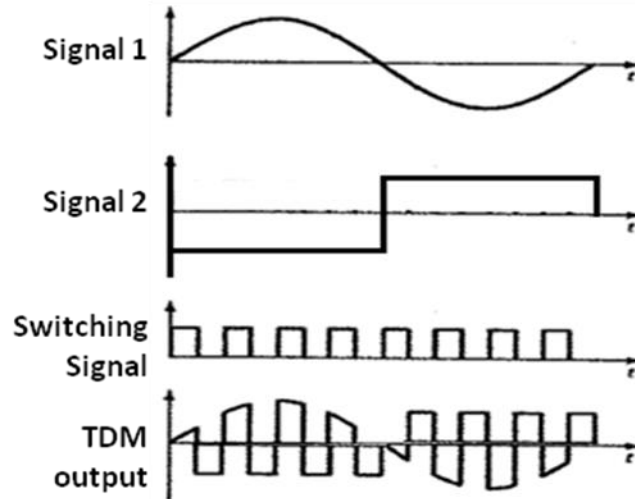

RESULT:

TDM Multiplexer and demultiplexer circuits were set up and the waveforms were plotted.

INFERENCE: Learned the basic idea of TDM multiplexing and demultiplexing.

Note: The demultiplexed outputs should be perfect sine and square waves. But with the given demultiplexer, the signal 2 output won't be a perfect square wave. An Op Amp comparator can be employed to make the output a perfect square wave.

Experiment No.10

PRE-EMPHASIS AND DE-EMPHASIS

AIM:

To design and set up pre-emphasis and de-emphasis circuits using Op amp and to plot the gain Vs frequency characteristics.

OBJECTIVES: After completing this experiment, the students will be able to a) design and set up pre-emphasis and de-emphasis circuits and to b) plot the response curve.

COMPONENTS AND EQUIPMENTS REQUIRED:

Sl. No.	Item & Specification	Quantity
1	IC 741	1No.
2	Resistor- 4.7K, 1K, 560Ω	1No.
3	Capacitor- 0.01μF	1No.
4	Signal Generator	1No.
5	CRO	1No.
6	Power Supply- +/- 15V	1No.
7	Bread Board	1No.

THEORY:

In FM Broadcasting, the effect of noise is more intense on higher frequencies than on low frequencies. Therefore, in order to have high signal-to-noise ratio (low noise), the high frequencies are amplified at the transmitter side (pre-emphasis) and for compensation, de-emphasis (decreasing the amplitude of those boosted frequencies) is done at receiver.

The pre-emphasis circuit is actually a high pass filter and de-emphasis circuit a low pass filter. The amount of pre-emphasis and de-emphasis used is defined by the time constant of a simple RC filter circuit. As per European standards $50\mu\text{s}$ is the time constant. In North America, $75\mu\text{s}$ is the standard value. Simple pre-emphasis and de-emphasis circuits using Op Amp are given in the diagram.

DESIGN:

Time constant chosen, $T = 50\mu\text{s}$

Therefore the time constant $RC = 50\mu\text{s}$

Take $C = 0.01\mu\text{F}$, then $R = 4.7\text{K}\Omega$

For Butterworth filters, Gain $A = 1.586$

Gain of non-inverting amplifier $= 1 + R_f/R_1$

$$1.586 = 1 + R_f/R_1$$

$$R_f/R_1 = 0.586$$

Take $R_1 = 1\text{K}$, then $R_f = 560\Omega$

PROCEDURE:

1. Test all the components and probes.
2. Set up the pre-emphasis circuit on a bread board as shown in figure.
3. Feed 5Vpp sine wave as input. Vary the frequency from 50Hz to 3MHz and note down the values of the corresponding output voltage on a tabular column.
4. Plot frequency response on a graph sheet with $\log f$ on x-axis and gain in dB on y-axis. Mark the cut-off frequencies corresponding to 3dB points.
5. Repeat the above steps for de-emphasis circuit.

CIRCUIT DIAGRAM:

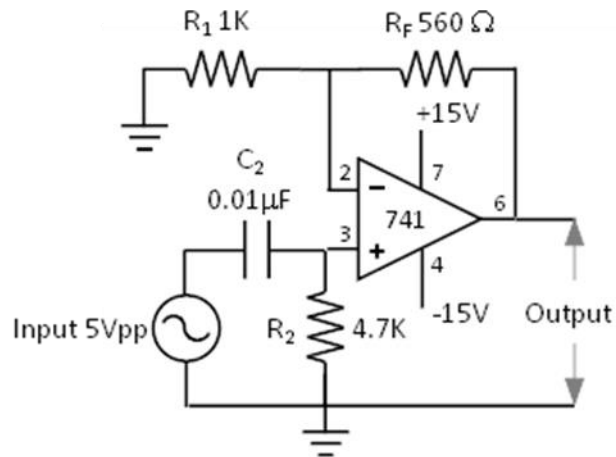

Pre-emphasis Circuit

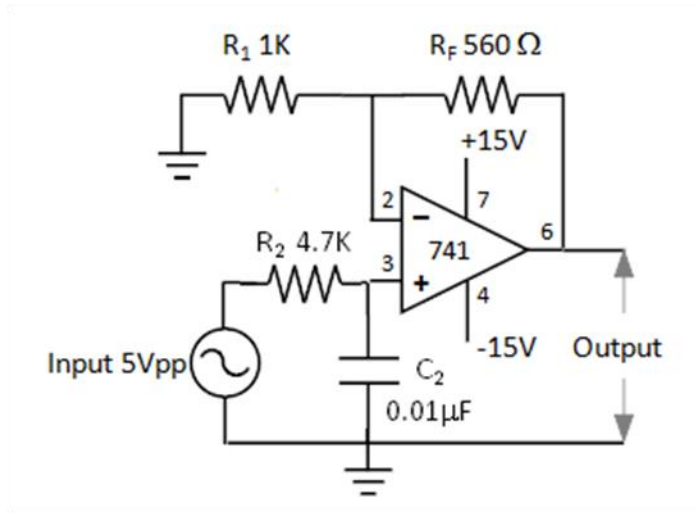

De-emphasis circuit

TABULAR COLUMN:

f (Hz)	V_o	log f	Gain in dB ($20\log V_o/V_i$)

FREQUENCY RESPONSE:

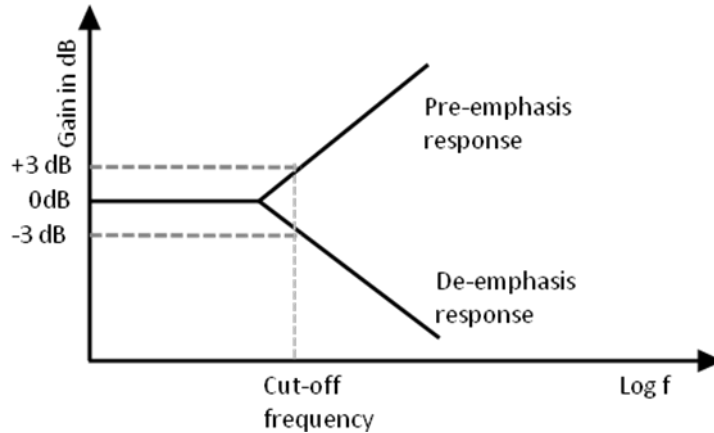

RESULT:

Pre-emphasis and de-emphasis circuits were set up and frequency response curves were drawn.

Cut-off frequency (3dB) for pre-emphasis circuit =

Cut-off frequency (3dB) for de-emphasis circuit =

INFERENCE: Signal to noise ratio at high frequencies can be considerably improved by employing pre-emphasis and de-emphasis.

Experiment No.11

TRANSISTOR MIXER

AIM:

To set up a transistor mixer circuit to produce IF from RF and oscillator frequency inputs and to measure the conversion transconductance.

OBJECTIVES:

After completing this experiment, the students will be able to a) set up a transistor mixer circuit and to b) study the relation between the RF, oscillator frequency and IF and to c) measure the conversion transconductance.

COMPONENTS AND EQUIPMENTS REQUIRED:

Sl. No.	Item & Specification	Quantity
1	Resistor- 22K, 33K, 3.3K	1No. each
2	Transistor BF194	1No.
3	Capacitor- 0.1 μ F	1No.
4	IFT	1No.
5	Signal Generator	2Nos.

6	CRO	1No.
7	Power Supply- =12V	1No.
8	Multimeter	1No.
9	Bread Board	1No.
10	Wires and probes	

THEORY:

Mixer or frequency convertor is actually a non linear resistor having two sets of input terminals and one set of output terminal. The two inputs to the mixer are the input signal and the local oscillator signal. The output of the mixer contains many frequencies including the sum and difference frequencies between the two input signals. The mixer output is commonly tuned to the difference frequency. This frequency is called the intermediate frequency (IF).

The input to the mixer is the input signal voltage with magnitude V_S and frequency f_S . The output is usually a current component at IF frequency having a magnitude I_{IF} proportional to V_S . The proportionality constant is called transconductance and is given by

$$g_C = I_{IF} / V_S$$

The conversion transconductance of a transistor mixer is of the order of 6ms. Mixing takes place when the transconductance of the mixer is caused to vary with the local oscillator voltage.

PROCEDURE:

1. Test all the components and probes.
2. Set up the circuit as shown in figure on a breadboard.
3. Switch on the power supply.
4. Check the dc conditions of the transistor and make sure that it is working in the active region.
5. Feed a 2Vpp, 100KHz sine wave signal at the base of the transistor as shown in figure.
6. Feed a 2Vpp, 555KHz sine wave signal at the emitter of the transistor as shown in figure.
7. Observe the output waveform on a CRO and measure the frequency. Adjust the IFT to obtain 455KHz as the peak output frequency.
8. Plot the input/output waveforms.
9. Measure the output ac current (I_{IF}) and the input ac voltage (V_S) using a multimeter.

Calculate the transconductance using the equation $g_C = I_{IF} / V_S$

10. Check the output for 100KHz and 355KHz inputs.

Note: The IFT centre tap point should be connected to Vcc. Connect one of the other two terminals of the IFT primary to the collector of the transistor. Try both terminals and select the one that gives the better output.

CIRCUIT DIAGRAM:

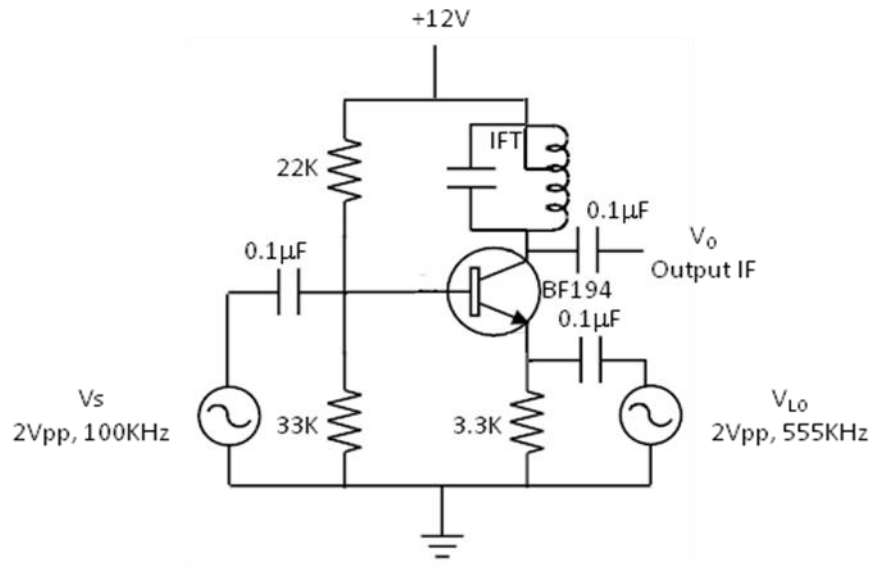

Transistor Mixer

WAVEFORMS:

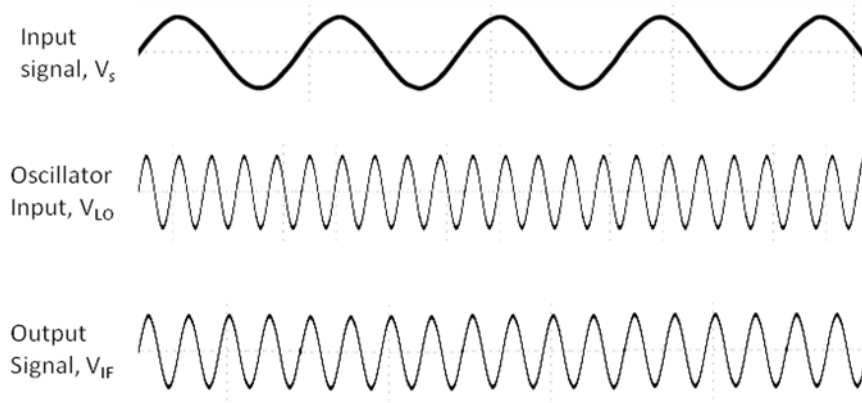

RESULT:

The Mixer circuit was set up and the waveforms were plotted.

Frequency of the IF signal =

Conversion transconductance, g_c =

INFERENCE:

- 1) The transistor in a mixer circuit is acting as a non linear resistor.
- 2) The IF is the frequency difference between the local oscillator frequency f_{LO} and the input signal frequency f_s .

PIN DIAGRAMS

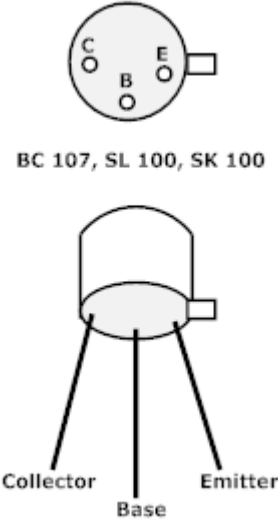
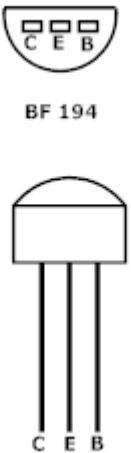
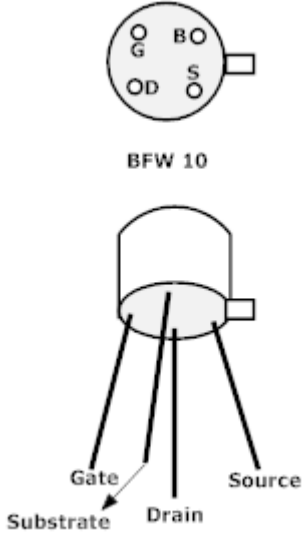
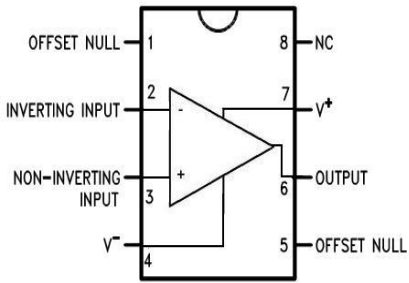
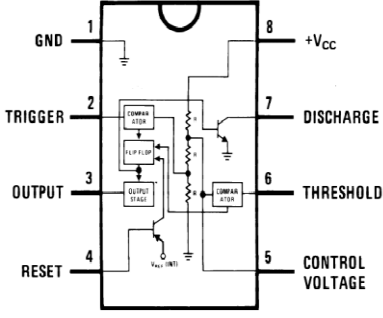
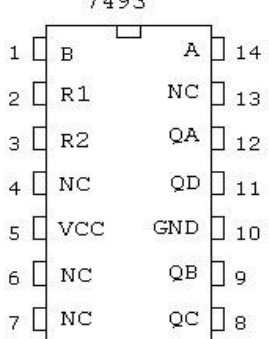
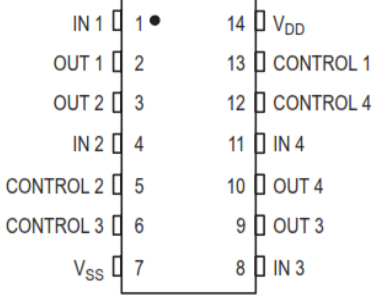
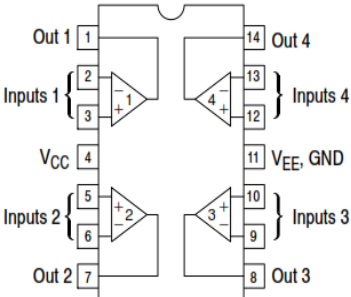
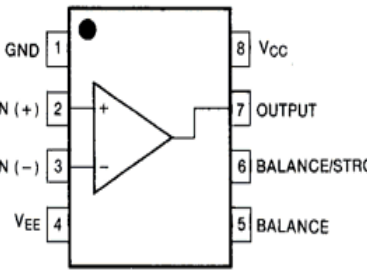
BC 107, SL 100, SK 100	BF 194	BFW 10
 <p>BC 107, SL 100, SK 100</p> <p>Collector Base Emitter</p>	 <p>BF 194</p> <p>C E B</p>	 <p>BFW 10</p> <p>Gate Drain Source</p> <p>Substrate</p>
IC 741	IC 555	IC 7493
<p>LM741 Pinout Diagram</p>  <p>OFFSET NULL 1 8 NC</p> <p>INVERTING INPUT 2 7 V^+</p> <p>NON-INVERTING INPUT 3 6 OUTPUT</p> <p>V^- 4 5 OFFSET NULL</p>	 <p>LM555 Timer</p> <p>GND 1 8 $+V_{CC}$</p> <p>TRIGGER 2 7 DISCHARGE</p> <p>OUTPUT 3 6 THRESHOLD</p> <p>RESET 4 5 CONTROL VOLTAGE</p>	 <p>7493</p> <p>1 B 14 A</p> <p>2 R1 13 NC</p> <p>3 R2 12 QA</p> <p>4 NC 11 QD</p> <p>5 VCC 10 GND</p> <p>6 NC 9 QB</p> <p>7 NC 8 QC</p>
CD 4016	LM 324	LM 311
 <p>IN 1 1 14 V_{DD}</p> <p>OUT 1 2 13 CONTROL 1</p> <p>OUT 2 3 12 CONTROL 4</p> <p>IN 2 4 11 IN 4</p> <p>CONTROL 2 5 10 OUT 4</p> <p>CONTROL 3 6 9 OUT 3</p> <p>V_{SS} 7 8 IN 3</p>	 <p>Out 1 1 14 Out 4</p> <p>Inputs 1 { 2 3 } Inputs 4</p> <p>V_{CC} 4 11 V_{EE}, GND</p> <p>Inputs 2 { 5 6 } Inputs 3</p> <p>Out 2 7 8 Out 3</p>	 <p>GND 1 8 V_{CC}</p> <p>IN (+) 2 7 OUTPUT</p> <p>IN (-) 3 6 BALANCE/STROBE</p> <p>V_{EE} 4 5 BALANCE</p>

