



|    |   |       |
|----|---|-------|
| 13 | Select the types of UPS?<br>d) Static, Dynamic and Hybrid                           | M 3.1 |
| 14 | The function of Rectifier component in UPS is?<br>c) AC to DC conversion            | M 3.1 |
| 15 | Working Principle of OFF-Line UPS?<br>Directly from mains without active conversion | M 3.1 |
| 16 | Online UPS utilizes the technology called?<br>Double or Delta Conversion Technology | M 3.1 |
| 17 | Solar Cell is a ?<br>Photovoltaic cell  | M4.1  |
| 18 | Solar cell is a ?<br>b) PN Junction   | M4.1  |
| 19 | 95% of Solar modules are composed of ?<br>c) Si                                     | M4.1  |
| 20 | A single solar cell can generate a voltage output?<br>d) 0.5 to 0.6v                | M4.1  |

1. Briefly explain the process of signal peaking using Digital Satellite Finder

A satellite finder can be used for aligning the satellite TV dish without having to take our receiver outside. It will great help in optimizing the dish antenna alignment precisely, once after the satellite is located.



The low noise block (LNB) down-converter used for satellite reception (digital or analogue) does not just receive a single channel; it receives the complete range from all transponders that are operating on a particular satellite. Together with the high gain a modern LNB feeds a lot of RF energy to the receiver when the dish is correctly aligned. Digital satellite finder measures the amount of RF energy over a wide frequency range by summing the power from all transponders and producing Received Signal Strength Indicator (RSSI) output, by means of proportionate DC voltage for display.

Simply plug the unit in to the dish and use the signal level bars to align you dish and once the level bars go green and the signal beeper is sounding the dish is aligned correctly and you are on the correct satellite. Start with the azimuth direction and try swinging the dish either side of the satellite till you lose the signal. You need to identify two points on either side where the signals are down by exactly the same amount (on your meter) and then put the dish in the exact centre.

## 2. Satellite Communication

A satellite system is a set of gravitationally bound objects in orbit around a planetary mass object (incl. sub-brown dwarfs and rogue planets) or minor planet, or its barycenter. A satellite definition is a small object that rotates in the region of a larger object within space. The best example of a natural satellite of the globe is the moon. We know that communication is nothing but the sharing of data among two or more entities using any transmission channel or medium. Alternatively, communication can also be defined as transmitting, receiving & processing the data. So, if communication occurs between any two stations on the earth with a satellite, then it is known as satellite communication. In this kind of communication, electromagnetic waves are utilized like carrier signals to carry the data like audio, voice, video among space and ground.

**Need of Satellite Communication:** In earlier communication, there are two types of propagation is used up to some distance like ground wave propagation and skywave propagation. The bandwidth used by Ground wave propagation is up to 30MHz frequencies. This kind of communication uses the conditions of the troposphere of the globe. The bandwidth used by skywave propagation mainly ranges from 30 to 40 MHz with the properties of the ionosphere of the earth. The highest station distance is restricted to 1500KM simply in both the propagations. So, satellite communication conquers this drawback. By providing long-distance communication.

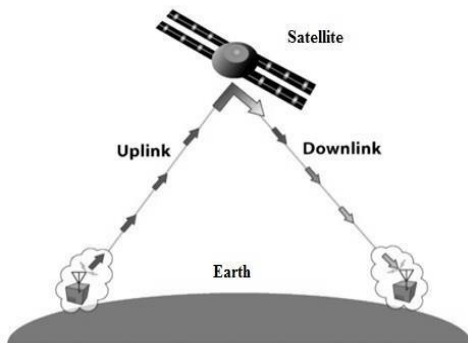

As the satellites situate at a certain height from the earth, then communication occurs in between two earth stations simply through satellite. So, it conquers the drawback of communication between two stations on the earth because of the curvature of the earth.

### Block Diagram

Satellite communications are related to the space mirrors because they assist us in activating the signals like internet data, radio & TV from one face of the earth to another face.

The **block diagram of the satellite communication system** includes the following. This satellite communication system can be explained through three blocks namely uplink, transponder, and downlink where these components of the satellite communication system & their working are discussed below.

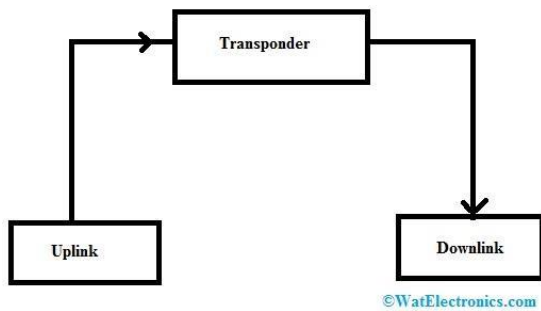

Let us consider the signals from a TV. In the primary phase, the signal transmits from the television to the other face of the earth & first carries to the satellite from the earth station over the earth. So this kind of procedure is called an uplink. The second stage is transponder like amplifiers, transmitters & radio receivers. The main function of a transponder is to boost the inward signal as well as to modify its frequency so that the leaving signals are not changed. Based on the incoming sources of signal, the transponders will change. The final stage includes a downlink where the data is transmitted to the receiver end on the globe. It is significant to recognize that generally there is a single uplink & several downlinks.

### 3. Components of DTH Technology

DTH (Direct to Home) System consists of the following components:

Dish Antenna , LNBF (Low Noise Block Down Converter plus Feedhorn) , Coaxial Cable ,Set Top Box

Dish Antenna : It is a Parabolic Reflector. It receives the signal and redirects it to the LNBF which works as receiver for signal transmitted by satellite Parabolic Reflector.

LNBF (Low Noise Block Down Converter Feedhorn) : Small metal horn antenna on the Dish is called as Feedhorn. It collects the signal from dish and amplifies the signal bouncing off the dish and filters out the noise (signals not carrying programming).

Coaxial Cable: It is the Cable that connects mini Dish and Set Top Box.

DTH Set Top Box: DTH Set Top Box, unlike the regular cable connection, decodes the encrypted transmission data and converts these signals into audio & video signal.

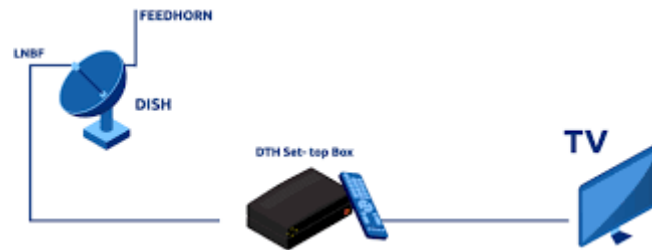

#### 4. Shortly discuss the process of OF Cable Splicing

- Write down the steps for cable preparation?
- Write down the steps for Optical Fiber splicing?

Put on the fusion splice protection sleeve.

Strip the fiber. ...

Cleave the fiber. ...

Put the fibers into the fiber holders in the fusion splicer. ...

Heat shrink the protection sleeve to protect the splicing joint.

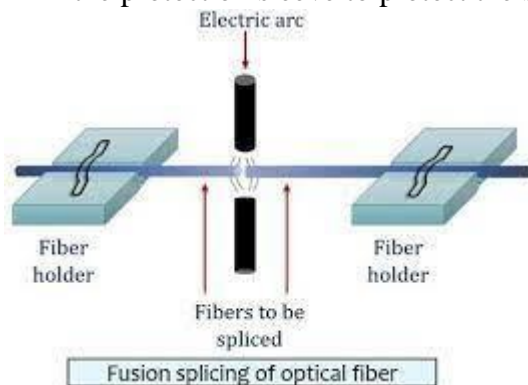

#### 5. FTTH

Fiber to the home (FTTH), also called fiber to the premises (FTTP), is the installation and use of optical fiber from a central point directly to individual buildings such as residences, apartment buildings and businesses to provide high-speed internet access.

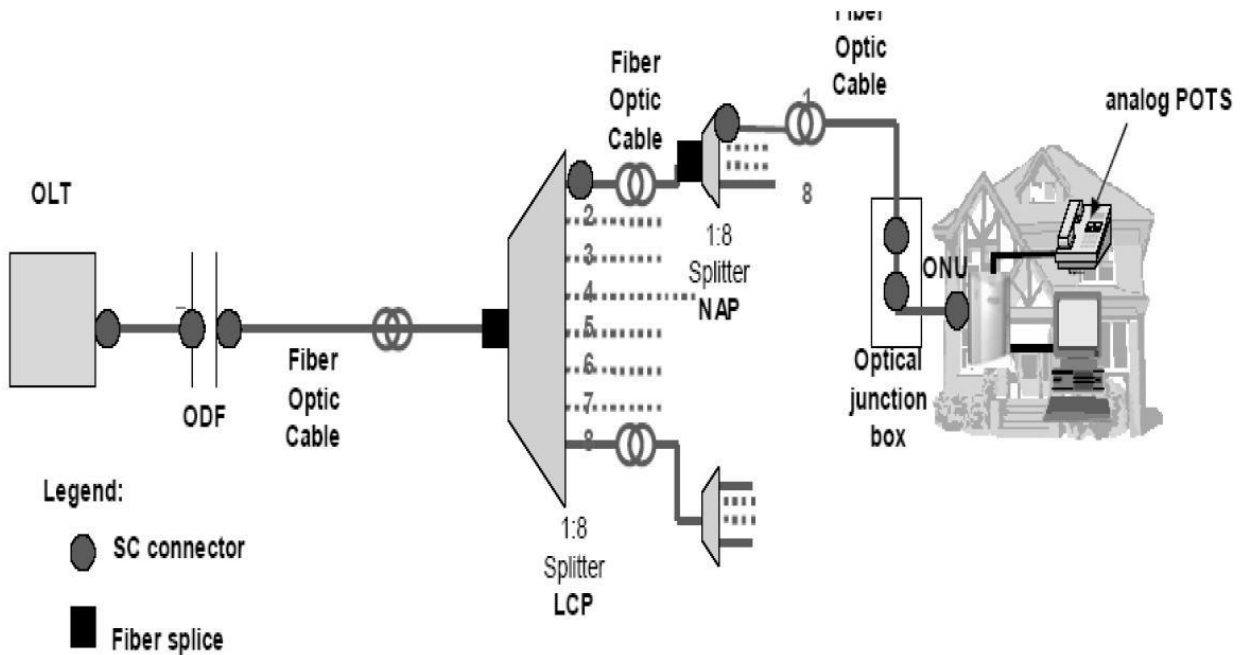

6. What is optical fiber modem and explain its working

A fiber optic modem (FOM) acts as a connecting interface between an electronic device and an internet network. These modems are different than regular DSL modems because the signal transmission is not via copper cables. It uses a fiber optic cable network to transmit signals. It transforms electronic communication signals via a fiber-optic network

- The internet signal transmitted via fiber optic cables to the fiber optic modems.
  - The modem transforms the internet signals into electronic data.
  - This transmission is a full-duplex transmission. That means the data can be transmitted from the internet source to the electronic device and vice versa.

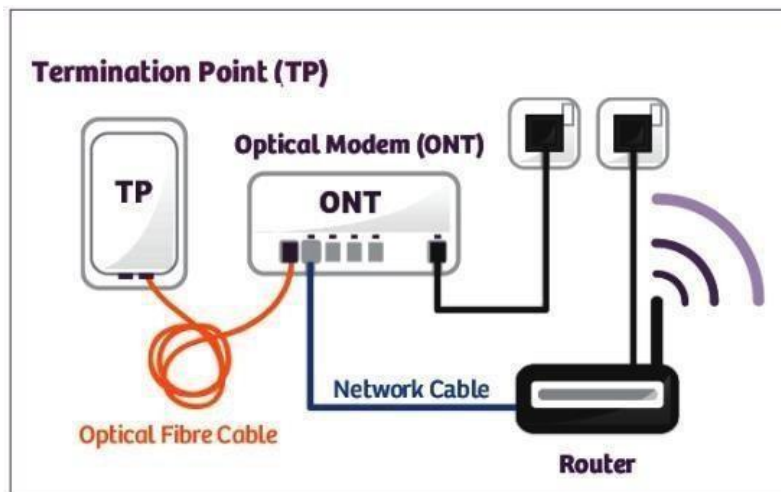

**ONT** is an interface between the Internet Service Provider (ISP) and the end user of fiber Internet. It's an integral part of the fiber optic internet system because it converts optical signals into information your computing devices can digest. In other words, it works as a modem if you get your broadband Internet through Fiber to the Premises (FTTP).

Most of the time, homes and offices already have coax cables installed. In that case, a cable modem and

router are the best fit. Otherwise, you must install expensive fiber cabling, **ONT**, and fiber routers to access an optical fiber internet connection.

**ONT** requires electrical power to operate and plugs directly into any existing AC electrical outlet in your facility. It converts incoming high-speed optical signals into electrical signals that your TV, telephone, and internet can comprehend.

Draw the block diagram and explain briefly Off Line UPS.

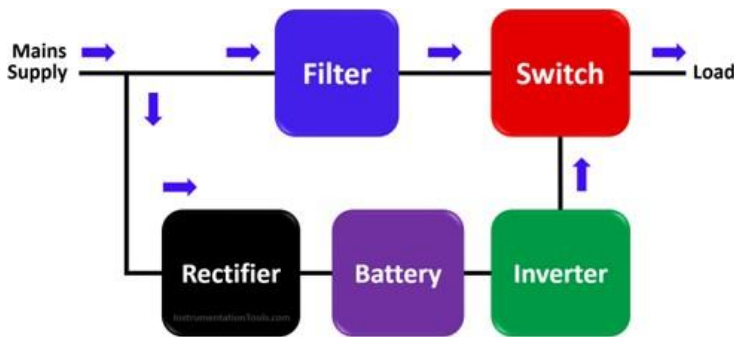

- Filter : Removes noise, unwanted signals.
- Rectifier: AC to DC conversion
- Battery: storage
- Inverter: DC to Ac conversion
- Swich: Switching between Mains and Inverter

Differentiate the 3 types of UPS.

- 1) Static ( Offline )  
It uses power electronic converters. High Efficiency
- 2) Dynamic ( Rotary)  
It uses electromagnetic engines. No switching time.
- 3) Hybrid  
A combination of both static and dynamic. Lower electricity consumption

Draw the block diagram and explain briefly Inverter.

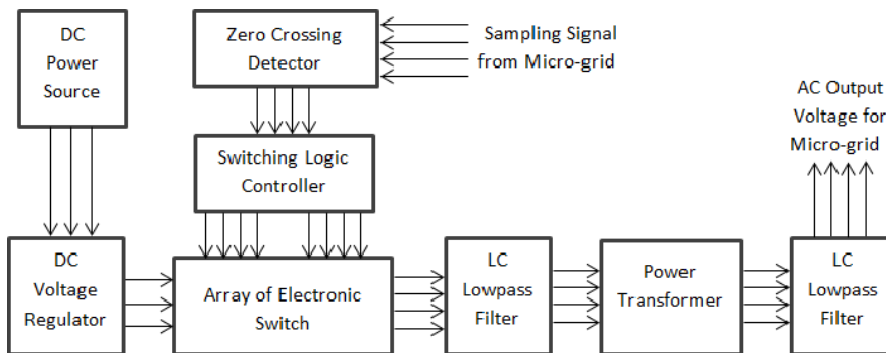

- DC voltage Regulator: Provide stable voltage.
- Filter: To remove noise and unwanted signals.
- Transformer: Changing voltage level.

List any 3 applications of UPS and any 2 applications of Inverter

#### UPS applications

- Data Centers
- Industries
- Telecommunications
- Hospitals
- Banks and insurance

#### Inverter Applications

- Electric motor speed control
- Power grid.
- Solar.
- Induction heating.
- HVDC power transmission.
- Electroshock weapons.

Draw and Explain Solar cell VI characteristics.

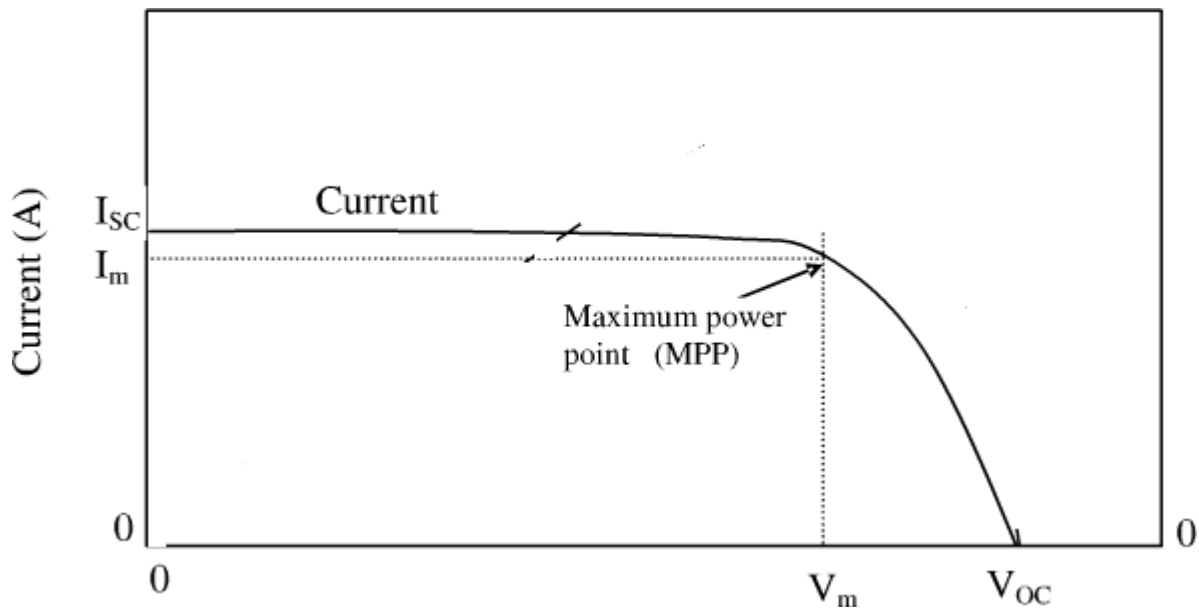

**I<sub>sc</sub>** is the short circuit current and it is measured by short circuiting the terminals. **V<sub>oc</sub>** is the open circuit voltage and it is measured when no load is connected. **P<sub>m</sub>** is maximum power, **I<sub>m</sub>** is maximum current, **V<sub>m</sub>** is maximum voltage and it occurs at the bend of the characteristic curve.

Explain the step by step working of a Solar panel.

- 1) Sun gives off light
- 2) Photo Voltaic cells on the panels turn the light into DC electricity.

- 3) The current flows into an inverter.
- 4) Inverter converts it into AC electricity.
- 5) Current is fed through a Meter and then to Consumer Unit.