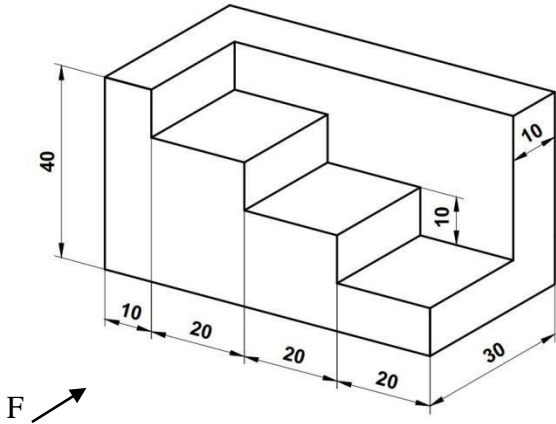
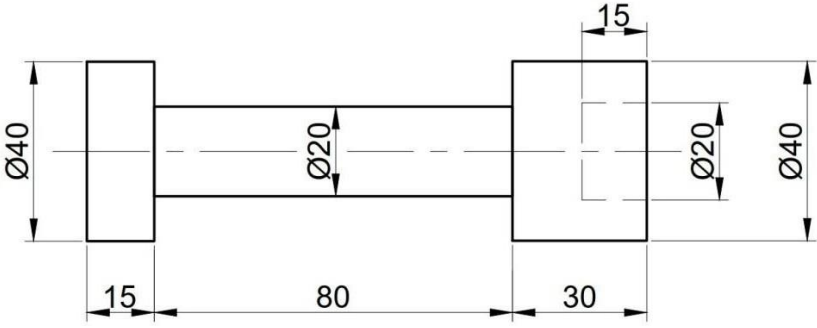

11	For orthographic projection, the engineering custom Bureau of Indian Standards dictates the use of? a) 1 st angle projection b) 2 nd angle projection c) 3 rd angle projection d) 4 th angle projection	M 3.1
----	---	-------

Q No	Question	Module
	in front of VP (1 st quadrant, parallel to both HP&VP). Draw its front and top view?	
8	What are the differences between first and third angle projection. Show the drawing symbols used in first angle and third angle projection?	M 3.1
9	<p>A stepped block is shown in below fig. Draw its front view?</p> 	M 3.1
10	Draw a hexagonal nut and bolt assembly for size M24?	M 4.1
11	Draw isometric view of a square prism, side of base 40mm and length 70mm when the axis of the prism is horizontal. Assume that the adjacent side of the base is equally inclined to vertical and horizontal planes?	M 4.1
12	<p>A simple machine pin is given in the below drawing. Prepare a shop floor drawing of the same by showing surface roughness, dimensional tolerance, geometrical tolerance (as a minimum) by assuming required data?</p> 	M 4.1